

MODULAR NEEDLE NOZZLE

HIRT-LINE



The expandable and individual configurable Hirt-Line needle nozzles!

Hirt[®]
LINE

NEEDLE NOZZLE 96mm

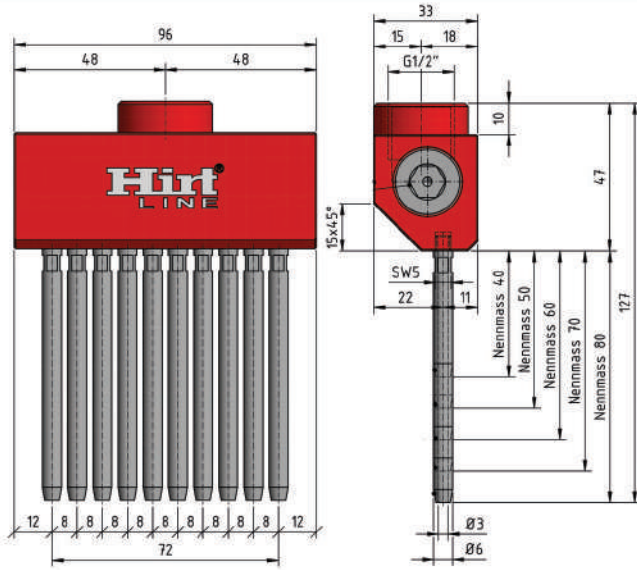

Part-No.: 2-NA-DU-96

Needle Nozzle for Hirt-Line Type2
Width 96 mm Base body
Nozzle openings Ø3,0mm
Connection 1/2" female thread
Material 1.4305 V2A / aluminium
Weight 357g

Incl. 10 pcs. screw-in nozzles
according to choice l= 40 - 80mm.

NEEDLE NOZZLE 192mm

Part-No.: 2-NA-DU-192

Needle Nozzle for Hirt-Line Type2
Width 192 mm Base body
Nozzle openings Ø3,0mm
Connection 1/2" female thread
Material 1.4305 V2A / aluminium
Weight 672g

Incl. 22 pcs. screw-in nozzles
according to choice l= 40 - 80mm.

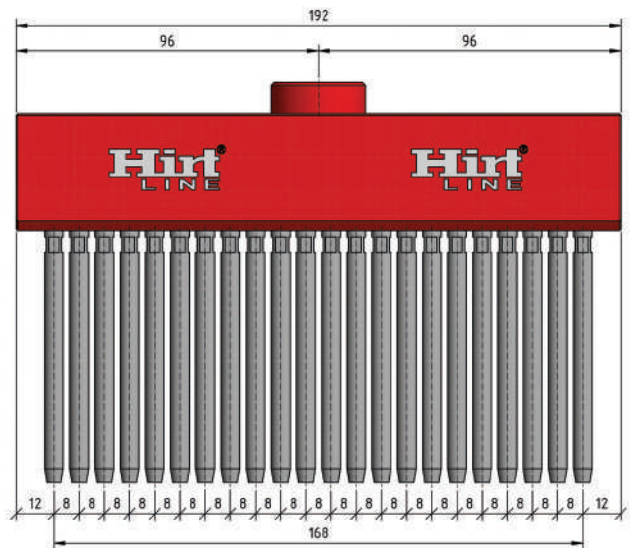
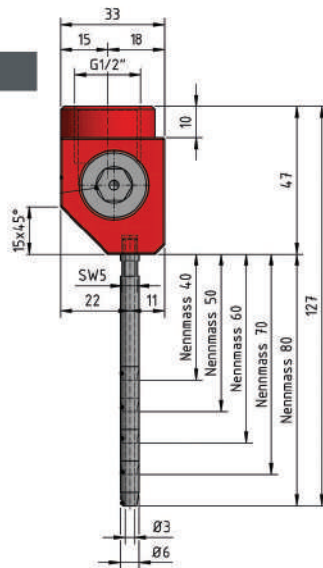

Part-No.: 2-NA-ANB-Set

Mounting set to extend as desired
the basic body

Consisting of fixed position,
Adjustment position, connector,
Assembly tool, closing cap.

Incl. sealing ring G1/2" and 2 pcs.
nozzles of your choice

Note!

To adapt the needle nozzles with our Hirt-Line system, you also need an adapter and a basic element.

For Hirt-Line Type2 System you need 1x 2-AD-12 + 1x 2-GE-DK, for Hirt-Line Type3 you need an additional reduction RE-3-2.