

## SELF CLEANING FILTERS

MANUAL & AUTOMATIC  
SIZES 20MM (3/4") – 300MM (12")



 **AIRPEL®**



# SELF CLEANING FILTERS – Manual & Automatic

Self-cleaning filters are designed specifically to provide efficient filtration for liquids, including those of high viscosity, requiring continuous filtration without interruption to the flow during the cleaning process. There is no operator contact with the process fluid. High quality stainless steel elements are highly effective in removing contaminant particles as small as 25 micron ( $\mu\text{m}$ ).

The filter is available for either manual or fully automatic electric or pneumatic operation. The range of optional control devices makes it particularly suitable for continuous processes and for service with high contamination levels.

## BENEFITS

- No operator contact with liquid during cleaning operation.
- Minimised product loss – during both process production and system cleaning.
- Increased quality output – minimum disruption to product flow.
- Reduced contamination – less possibility of accidents or operator exposure to the fluid.
- Reduced maintenance costs – automated units eliminate manual cleaning.
- Environment friendly – enclosed design with minimal flushing losses.

## OPERATION

The liquid enters the body and flows through the element from outside to inside. Debris is collected on the outside of the wedge wire or perforated element, which is cleaned without flow interruption by the rotation of the element against the blades. The debris accumulated during rotation is deposited into the bottom of the filter body from where it is periodically discharged, manually or automatically.

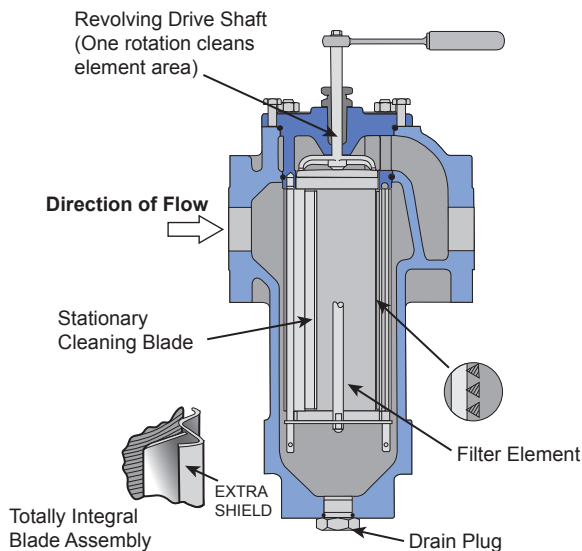

## TYPICAL APPLICATION

- Adhesives
- Chemicals
- Chocolate
- Cooling Lines
- HVAC Water
- Inks
- Lacquers
- Paints, Stains, Varnishes
- Petrochemicals
- Printing
- Recycling Water
- River & Sea Water
- Wash Water

## AUTOMATED SELF CLEANING FILTERS

The Airpel Filtration automated self cleaning filter allows for stand alone, low maintenance processing of liquids. The range can be automated, either electronically or pneumatically, from 32mm (1¼") and above. The filters can be supplied wired and fully tested, requiring only on site connection to the power source and dump valve connection.

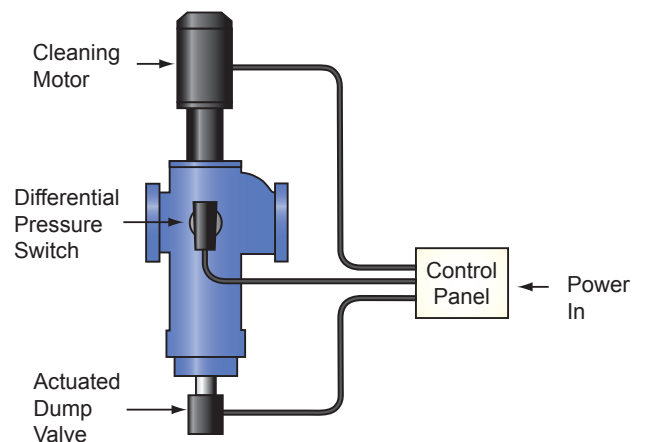

## RANGE

Airpel Filtration offer three forms of blade type self cleaning filters: standard range, high pressure range and rotor blade, all working on the same generic principle. Airpel also offer both standard element and high pressure element for very demanding duties. Fabricated units can also be provided, these contain multiple elements and are suitable for larger capacities.



S1

### HIGH PRESSURE

Models: 200, 300, 400 and 600 (2" – 6")  
Construction: cast  
Materials: iron, steel and stainless steel  
Working pressures: up to 35 bar  
Flow rates: up to 3000 litres/min



S2

### STANDARD PRESSURE

Models: 075, 100, 125, 150, 200, 300 and 400 (3/4" – 4")  
Construction: detachable head and bowl form  
Materials: cast iron and stainless steel  
Working pressures: up to 14 bar  
Flow rates: up to 1500 litres/min



S4

### ROTOR BLADE

Model: S4 Rotor Blade  
Construction: stainless steel  
Materials: stainless steel with stainless steel or plastic blades  
Working pressures: up to 14 bar  
Flow rates: up to 1000 litres/min



S2

### SPECIAL FABRICATED

Models: 800, 1000, 1200 (8" – 12")  
Construction: welded  
Materials: customer specification  
Working pressures: customer specification  
Flow rates: up to 18000 litres/min

\* S1, S2, and S4 are available as manual, motorised and fully automated

## SIZING CHART / PRESSURE DROP CHART

The chart is for water flowing through a filter without an element. Use the following correction factors for the chosen filtration rating and for liquids of higher viscosity.

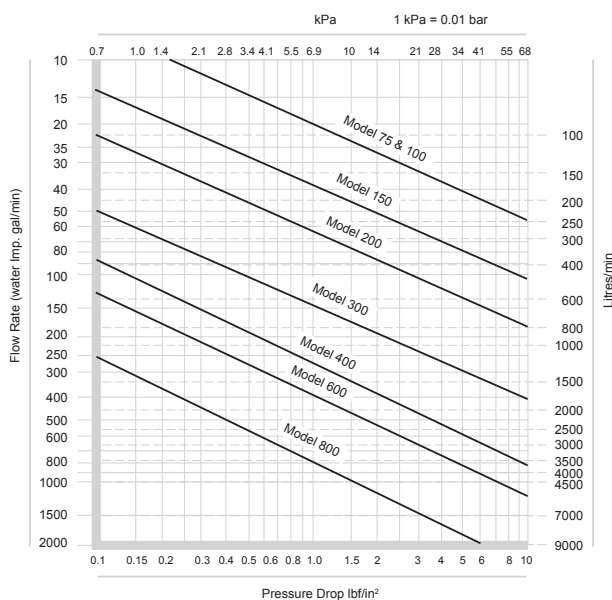

## CORRECTION FACTORS

Either – multiply the pressure drop for water shown in the chart by the following correction factors to obtain the actual pressure drop. (Water has a viscosity of 1 centistoke at 20°C) Or – divide the acceptable pressure drop by the necessary correction factor in the table below and then use the chart to determine the filter size and flow rate. All self cleaning products available in manual, motorised & fully automated

### CORRECTION FACTORS FOR

VISCOSITY CENTISTOKES	FILTRATION RATING				
	1000 µM	500 µM	200 µM	100 µM	50 µM
1	1	1	1.1	1.2	1.45
50	1.4	1.8	2.1	2.3	2.5
230	1.70	2.5	3.0	3.35	3.75
370	1.8	3.0	3.4	3.8	4.3
860	2.6	3.7	4.2	5.0	6.0

SPARE PARTS IDENTIFIER (S1 AND S2 MODELS)

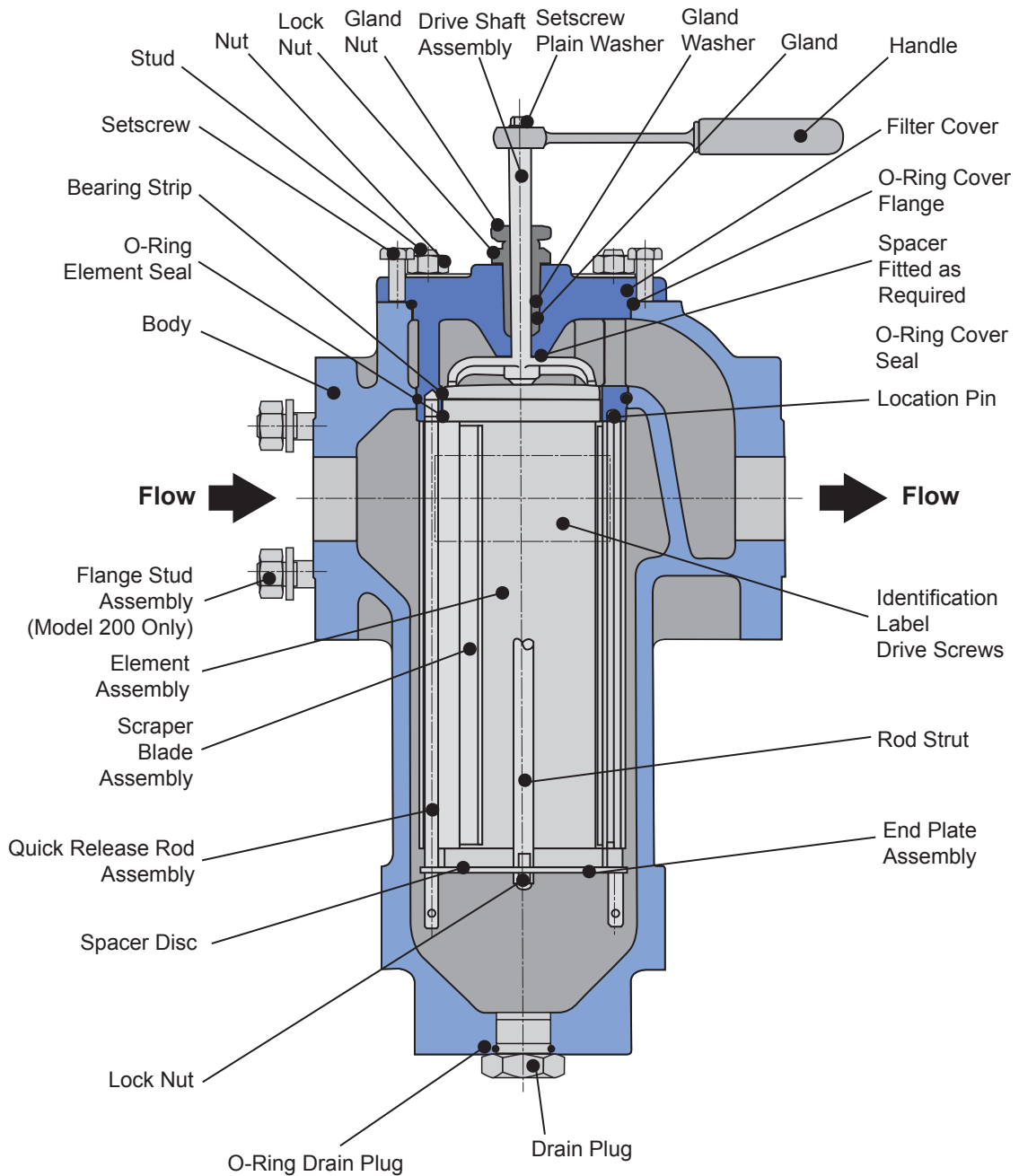

O-Rings, Gland Packing and Washers available only in Seal Kit

## MODEL S1 SELF CLEANING FILTER



### Flanged Filters (sizes in mm)

MODEL	A PIPE SIZE	B	C	D	E	F	G	H	J	K	L	M	N	P	R	S	WEIGHT MANUAL (KG)	WEIGHT AUTO (KG)
200	32(1 <sup>1</sup> / <sub>4</sub> " 50(2")	270	150	195	413	150	325	115	185	540	150	124	110	1" BSP	165	25	36kg	44kg
300	80(3")	360	210	230	560	180	430	140	185	575	180	124	142	2" BSP	210	22	60kg	68kg
400	100(4")	550	315	435	1115	340	665	235	285	880	332	—	142	2" BSP	254	30	164kg	On req.
600	150(6")	550	315	435	1550	340	1165	235	285	880	332	—	142	2" BSP	318	35	182kg	On req.

Models 800-1200 units are available as fabricated units comprising of multiple model 600 elements which are subject to process conditions. Please contact our Technical Sales Team for further information on these products.

\* The Model 200, 32mm — 50mm size units, also available in screwed version. Larger sizes upon request.

Model 400,

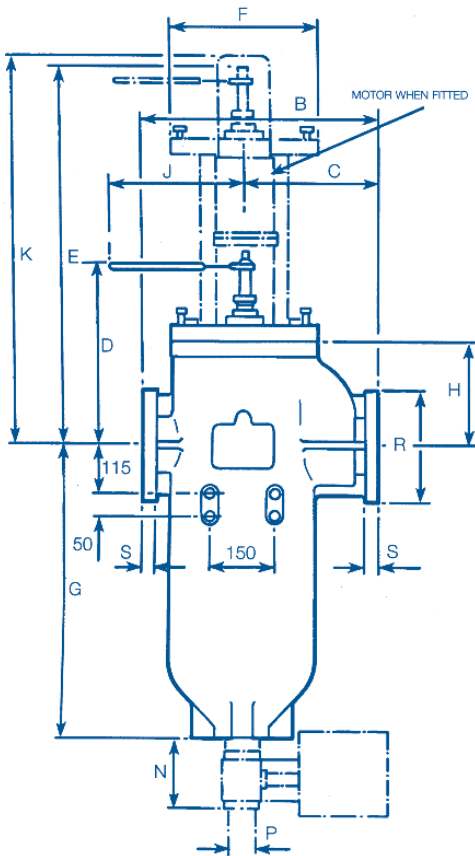

Model 200, 300

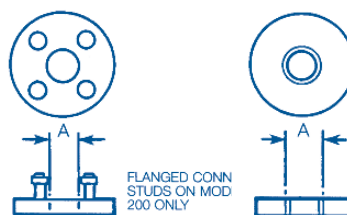
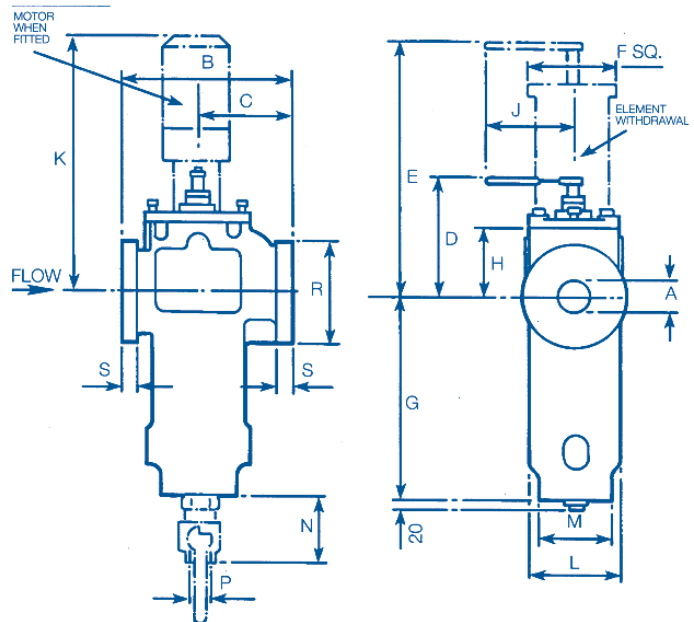

Connections Model 200 only

## MODEL S2 SELF CLEANING FILTER



### Screwed Filters (sizes in mm)

Model	A	B	C	D	E	F	G	H	J	K	L	M	Weight (kg)
075	3/4" BSP	150	24	273	13	1/2" BSP	185	80	450	114	—	—	7kg
100	1" BSP	150	24	273	13	1/2" BSP	185	80	450	114	—	—	7kg
125	1 1/4" BSP	208	32	404	20	1" BSP	185	133	640	160	110	445	11.2kg
150	1 1/2" BSP	208	32	404	20	1" BSP	185	133	640	160	110	445	11.2kg
200	2" BSP	220	40	458	20	1" BSP	185	133	665	160	110	447	19kg

### Flanged Filters (sizes in mm)

MODEL	A	B	C	D	E	F	G	H	J	K	L	M	WEIGHT (KG)
125	1 1/4"	270	32	404	20	1" BSP	185	133	640	160	110	445	11kg
150	1 1/2"	270	32	404	20	1" BSP	185	133	640	160	110	445	11kg
200	2"	270	40	458	20	1" BSP	185	133	665	160	110	447	25.0kg
300	3"	300	56	575	20	2" BSP	185	148	895	190	160	46	41.0kg
400	Model 400 unit comprises of two times 300 units manifolded together. Please contact our Technical Sales Team for further information on this product.												

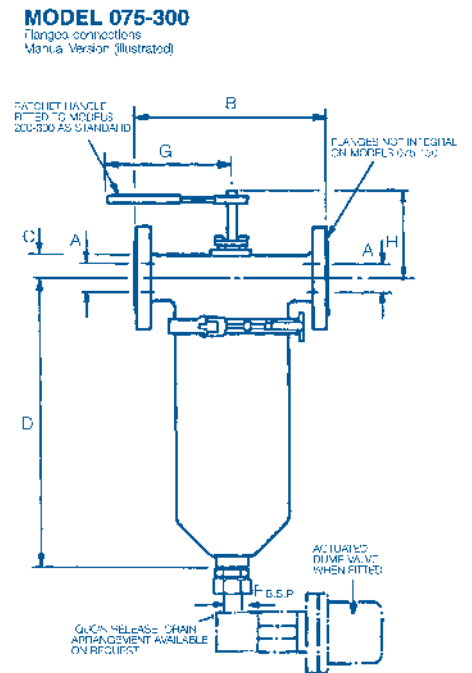
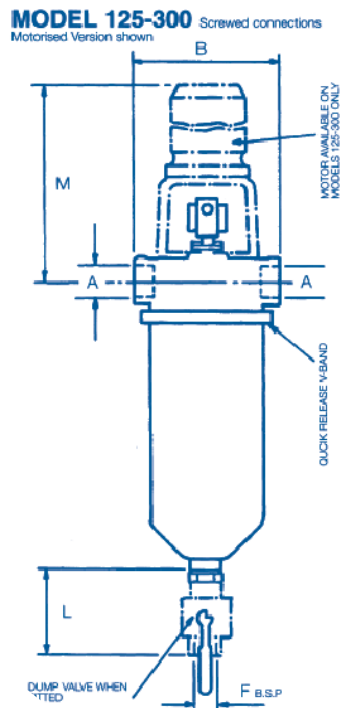
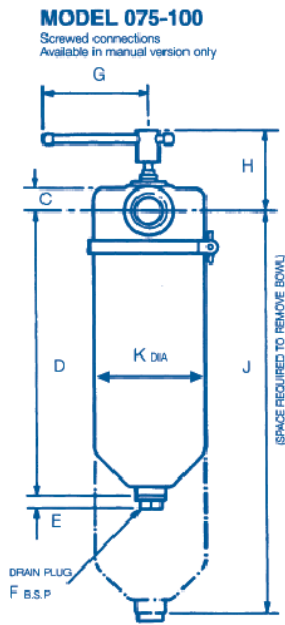

# MODEL S4 SELF CLEANING FILTER



## Screwed Filters (sizes in mm)

MODEL	A PIPE SIZE	B	C	D	E	F	G	H	J	K	L	M	N P		R	S
													BSP OR NPT			
150S	40(1 1/2")	260	178	400	75	155	570	855	130	100	270	240	1"	3/4"	87.5	12
200S	50(2")															
250S	65(2 1/2")	320	208	502	88	200	700	1135	160	118.5	330	240	2"	1 1/2"	160	15
300S	80(3")															

## Flanged Filters (sizes in mm)

Model	A Pipe Size	B	C	D	E	F	G	H	J	K	L	M	N P		R	S
													BSP or NPT			
150F	40(1 1/2")	300	178	400	75	155	570	855	130	100	270	240	1"	3/4"	87.5	12
200F	50(2")															
250F	65(2 1/2")	340	208	502	88	200	700	1135	160	118.5	330	290	2"	1 1/2"	160	15
300F	80(3")															
400F	Model 400 unit comprises of two times 300 units manifolded together. Please contact our Technical Sales Team for further information on this product.															

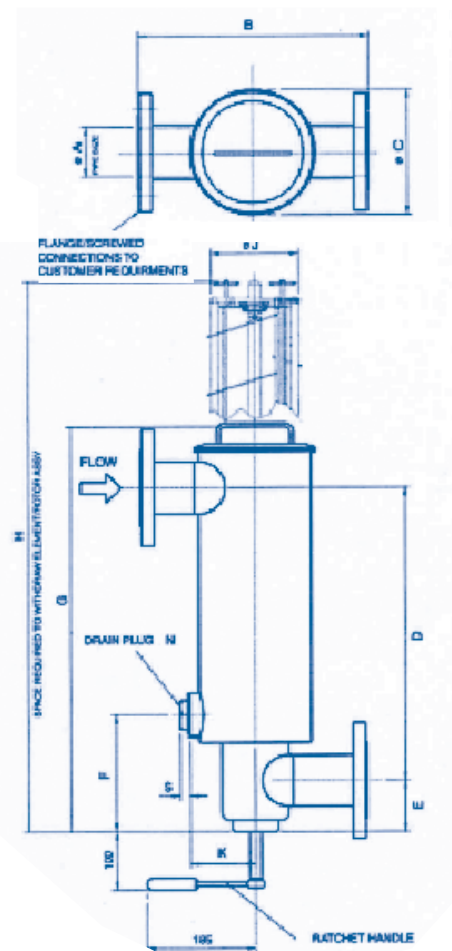

Hand-operated Unit

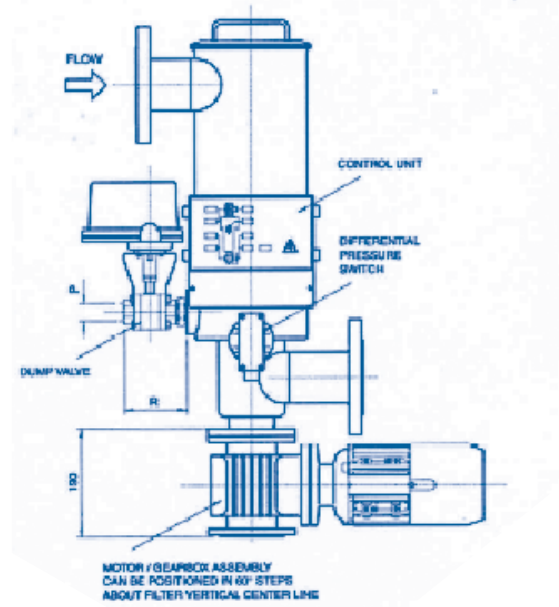
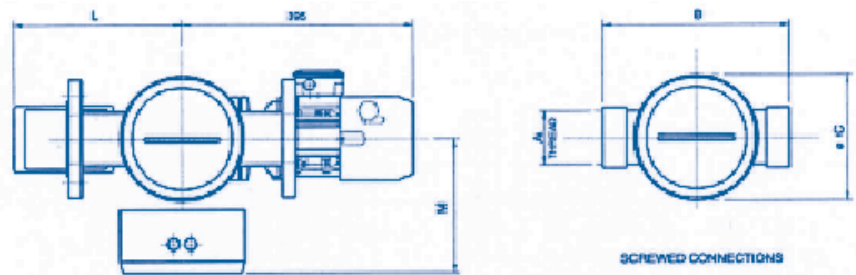

Automatic Unit



| SPEED  
| EXCELLENCE  
| PARTNERSHIP

 AIRPEL®

Hambridge Road  
Newbury, Berkshire,  
RG14 5TR,  
United Kingdom

P: +44 (0) 1635 263915  
F: +44 (0) 1635 36006  
E: [airpel@celerosft.com](mailto:airpel@celerosft.com)

*Celeros Flow Technology reserves the right to incorporate our latest design and material changes without notice or obligation. Design features, materials of construction, and dimensional data, as described in this bulletin, are provided for your information only and should not be relied upon unless confirmed in writing. Please contact your local sales representative for product availability in your region.*

*For more information, visit [www.celerosft.com](http://www.celerosft.com)*

*AP\_134\_03\_SCF\_GB Version 01/2020 Issued 12/2020*

*COPYRIGHT © 2020*

