

m&h LASER TOOL SETTERS

MEASURING ON MACHINE TOOLS





 **HEXAGON**

**LIGHT EMITTING DIODE
DO NOT STARE INTO BEAM
LASER CLASS 2**
Power: 4.1 mW
Wave length: 630 - 700 nm
Mfg by DSI EM 68025-1-2001-11

EXACT TOOL DATA FOR MAXIMUM ACCURACY

Consistent production quality requires the use of reliable accurate tooling. A vital requirement is precise tool data. m&h Laser tool setters determine the length and radius of the tools directly on the machine. The data is automatically transferred to the control's tool table. Periodic tool checks for breakage or wear provide additional production reliability. The Laser tool setters from m&h will do this job, efficiently and dependably.

TOOL MEASUREMENT

- Fast and precise measurement of tool length and tool radius
- Tools are measured in the actual clamping system at nominal speed
- Compensation of the tool diameter for dynamic changes in the rotational diameter of the tool

COMPENSATION OF MACHINE EFFECTS

- Correction of tool length in case of thermal change and thermal drift on the spindle or the machine axes
- Correction or monitoring of runout, tool change and clamping errors

TOOL BREAKAGE AND SINGLE CUTTING EDGE CONTROL

- Fast tool breakage detection
- Single cutting edge control for breakage or tool wear

MOULD TOOLS

- Measurement of tool length and tool radius
- Shape control and monitoring of the tool wear

ROBUST – PRECISE – RELIABLE

ROBUST CONSTRUCTION

- Shutter unit protects laser optics
- An air curtain eliminates any contamination due to dirt particles
- Measurement system sealed to IP68 standard

PRECISE AND RELIABLE

- Precise measurement of tool cutting edges under nominal rotational speed
- Ultrasonic cleaning nozzle prevents measurement errors due to adhesive particles
- No faulty software switching due to coolant drops
- No faults due to extraneous light



STATE-OF-THE-ART

HIGH-END LASER OPTICS (PREMIUM)

- Highly exposed focus point
- Minimum tool diameter: 8 μm
- Offers high alignment tolerance
- Exact tool setting

TCS – TRUE CUTTING SCAN FOR THE HIGHEST PRECISION

- Scans the really longest cutting circle
- Searches the longest cutting circle diameter
- Uses this to the exact length measurement
- High-end functionality – exclusively from m&h

TOOL CLEANING USING LAVAL NOZZLE

- Laval nozzle with supersonic pressure
- Tool cleaning in measuring position
- Tool cleaning with nominal rotation speed for optimum cleaning results
- Minimal cleaning distance
- Sealing cap prevents penetration of foreign objects and liquid

PNEUMATIC SHUTTER UNIT

- Complete closing shutter unit
- Cleaning by air blast without additional air pressure consumption
- Air curtain during the measuring process prevents soiling of the optic
- Reliable closing after measuring process

FAST TOOL BREAKAGE CONTROL

- No rejections due to worn-out tools
- Time savings thanks to m&h's fast tool breakage control
- High degree of reliability due to cyclical tool inspection

THE ALTERNATIVES YOU HAVE BEEN WAITING FOR

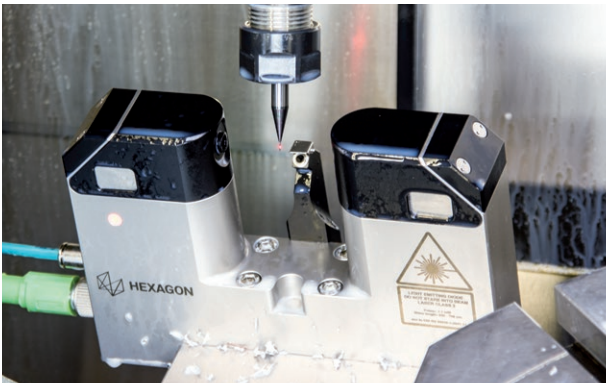

m&h LTS35.60 – PREMIUM

Premium laser tool setter for dynamic tool measurement. The tool setter measures tools as small as 0.008mm. With its high-end optics and its strongly focussed laser, every tool can be measured exactly. Simple assembly and alignment, robust stainless steel construction as well as the integrated m&h cleaning nozzle ensure the greatest precision and reliability in every manufacturing situation.

- TCS technology (True Cutting Scan)
 - for the highest precision
- Smallest tool diameter 8 μm
- Tool cleaning through laval nozzle with supersonic speed

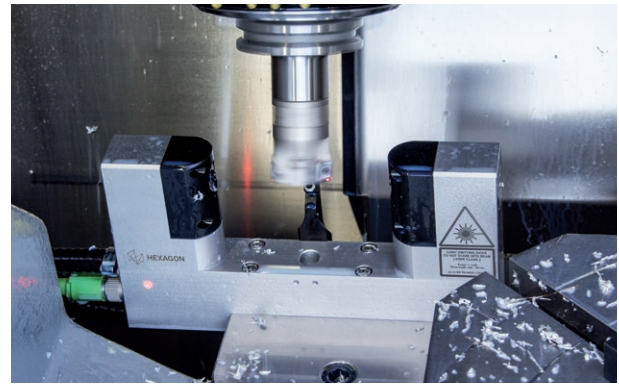

m&h LTS35.65 – STANDARD

The laser tool setter Standard, a cost-effective system for the majority of measuring tasks on tools from $\text{\O} 0.030 \text{ mm}$ and tool breakage detection with significant advantages compared to previous common standard instruments. An air curtain during the measuring process prevents soiling of the optics. The shutter units seal completely when the device is not in use. No additional interfaces or peripheral supply units are needed. The economical solution for most measuring tasks.

- TCS technology (True Cutting Scan)
 - for the highest precision
- Tool cleaning through laval nozzle with supersonic speed
- Optimal protection of the optics by means of pneumatic shutter unit

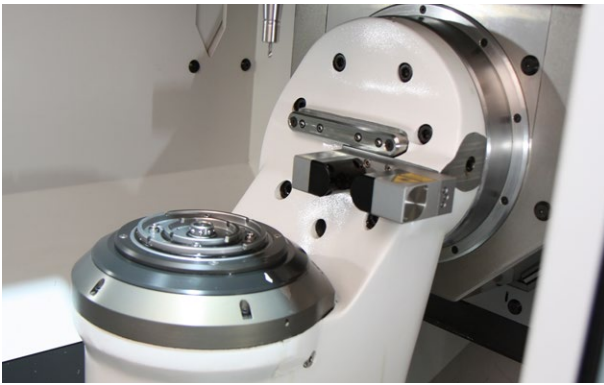

m&h LTS35.65-23 – COMPACT

The laser tool setter Compact is designed for usage in machines with a limited amount of space for the measurement of particularly small tools. With a length of 123 mm and a height of only 66 mm, there is space for the system even in a small machine. The cable outlet is also only downward to prevent the need for more space for cables and the pneumatic supply. The compact solution for tool measurement and break control.

- TCS technology (True Cutting Scan)
 - for the highest precision
- Compact laser measuring device
 - the smallest in its class
- Tool cleaning through laval nozzle with supersonic speed

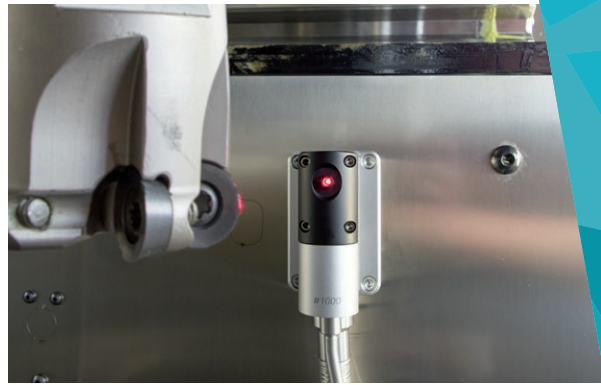

m&h LTS35.66 – SEPARAT

The laser tool setter LTS35.66, a cost-effective system for the majority of measuring tasks on tools from \varnothing 1 mm and tool breakage detection with significant advantages compared to previous common standard instruments. The laser tool measurement system LTS35.66 is characterised by the greatest degree of flexibility during installation and a simple commissioning procedure. Different assembly aids support the integration into the most varied types of machines. This compact, robust system is absolutely immersion-proof in accordance with IP68. Regardless whether in machining area or magazine, the pneumatic shutter unit reliably protects the optics against dirt, thereby minimizing maintenance. An air curtain during the measuring process prevents soiling of the optics.

- Flexible installation and simple adjustment
- Large range of application from 300 to 5000 mm
- Optimal protection of the optics by means of pneumatic shutter unit

TECHNICAL DATA

Dimensions	A	B
LTS35.65-90	90 (3.5")	200 (7.9")
LTS35.65-160	160 (6.3")	270 (10.6")
LTS35.65-300	300 (11.8")	410 (16.1")

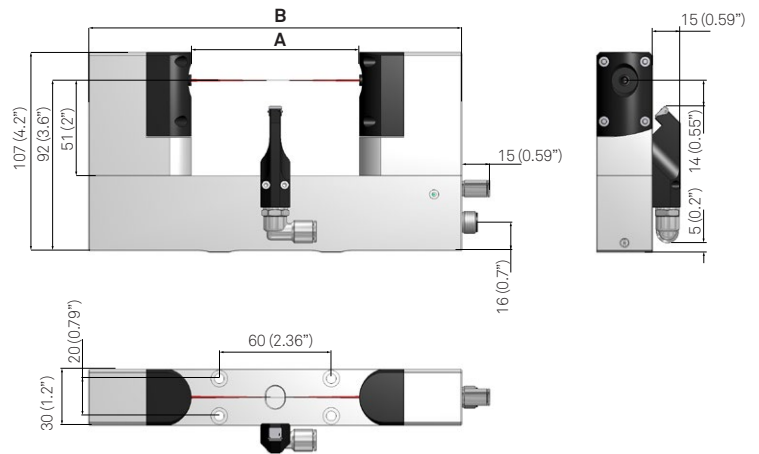
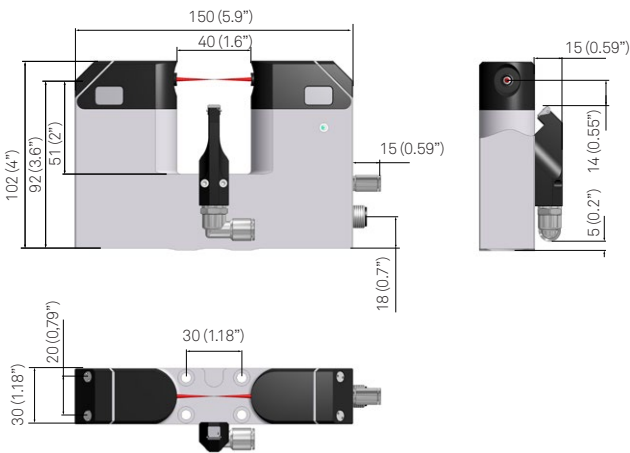

Description		
LTS35.60	Repeatability	0,1 µm (2 Sigma)*
	Power supply	24 VDC / max. 500 mA
	Laser	Centrally focused 639 nm / < 1 mW
	Laser safety class	2 (IEC825)
	Temperature range	Storage: 5 °C – 70 °C, Operating: 10 °C – 50 °C
	Material	Stainless Steel
	Protection class	IP68: EN60529 (connected, air-curtain on)
	Service life	> 1 million ON/OFF cycles tested

Description		
LTS35.65	Repeatability	0,1 µm (2 Sigma)*
	Power supply	24 VDC / max. 100 mA
	Laser	Centrally focused 650 nm / < 1 mW
	Laser safety class	2 (IEC825)
	Temperature range	Storage: 5 °C – 70 °C, Operating: 10 °C – 50 °C
	Material	Aluminium, hard coated
	Protection class	IP68: EN60529 (connected, air-curtain on)
	Service life	> 1 million ON/OFF cycles tested

* Depending on the application and installation situation

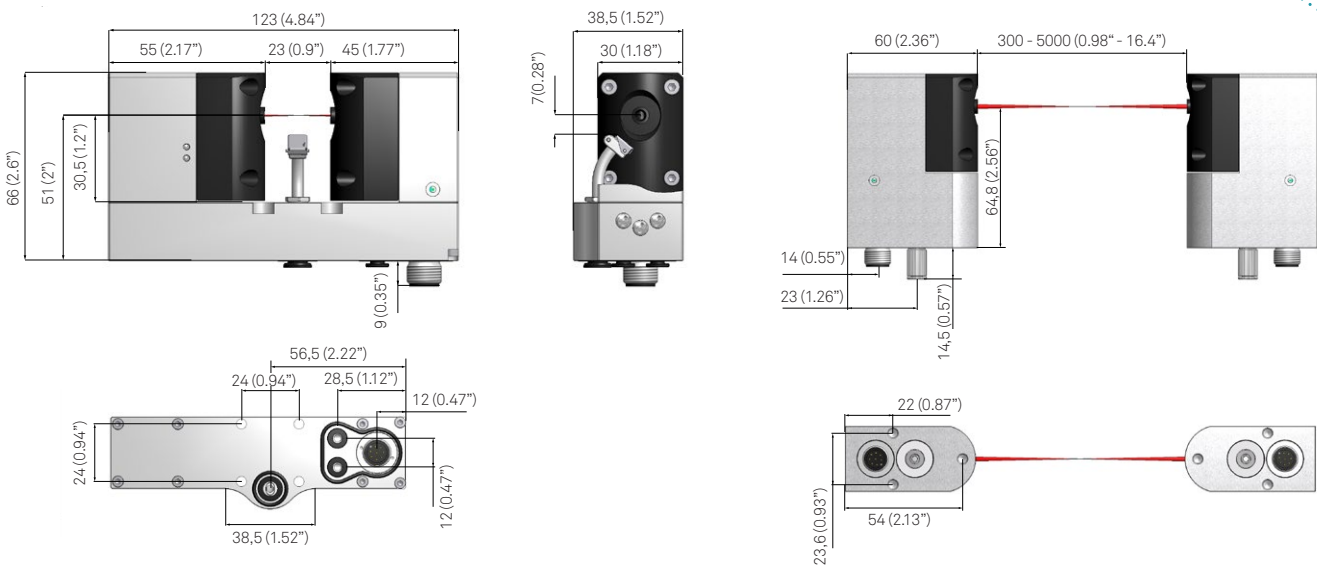

Description		
LTS35.65-23	Repeatability	0,1 µm (2 Sigma)*
	Power supply	12-26 VDC / max. 100 mA
	Laser	Centrally focused 650 nm / < 1 mW
	Laser safety class	2 (IEC825)
	Temperature range	Storage: 5 °C – 70 °C, Operating: 10 °C – 50 °C
	Material	Aluminium, hard coated
	Protection class	IP68: EN60529 (connected, air-curtain on)
	Service life	> 1 million ON/OFF cycles tested

Description		
LTS35.66	Repeatability (distance < 1000 mm)	0,1 µm (2 Sigma)*
	Power supply	12-25 VDC / max.100 mA
	Laser	Centrally focused 650 nm / < 1 mW
	Laser safety class	2 (IEC825)
	Transmitter/Receiver distance	0,3m - 5 m (±5 mm)
	Temperature range	Storage: 5 °C – 70 °C, Operating: 10 °C – 50 °C
	Material	Aluminium, hard coated
	Protection class	IP68: EN60529 (connected, air-curtain on)
Service life	> 1 million ON/OFF cycles tested	



LASER RADIATION
DO NOT LOOK INTO THE BEAM
CLASS 2 LASER PRODUCT
620-690 nm / 1 mW cw
applied standard: IEC 60825-1:2014

CUSTOMER STORIES

m&h's high-quality measurement systems are specially designed and made for use in tooling machines, impressing with their maximum precision and reliability. Here are extracts from testimonials by users of m&h Laser tool setters.

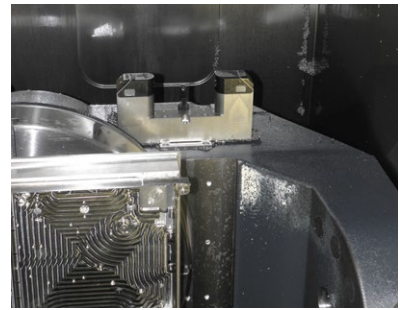
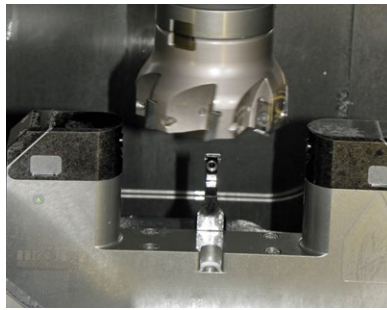



We achieve longer cutter lifetimes with fast breakage control, as we don't have to change tools as a precaution"

explains Andreas Dauderer
5AX PERFORMANCE, GERMANY



The air jet simply blasts away any dirt on edges. The laser optics lenses no longer need to be cleaned. The maintenance costs are also a lot lower. It's easy"

says Bernd Gruber of his experience
ERICH ROTHE GMBH & CO. KG, GERMANY





HEXAGON

MANUFACTURING INTELLIGENCE

Hexagon Manufacturing Intelligence helps industrial manufacturers develop the disruptive technologies of today and the life-changing products of tomorrow. As a leading metrology and manufacturing solution specialist, our expertise in sensing, thinking and acting – the collection, analysis and active use of measurement data – gives our customers the confidence to increase production speed and accelerate productivity while enhancing product quality.

Through a network of local service centres, production facilities and commercial operations across five continents, we are shaping smart change in manufacturing to build a world where quality drives productivity. For more information, visit HexagonMI.com.

Hexagon Manufacturing Intelligence is part of Hexagon (Nasdaq Stockholm: HEXA B; hexagon.com), a leading global provider of information technologies that drive quality and productivity across geospatial and industrial enterprise applications.



COORDINATE MEASURING MACHINES



3D LASER SCANNING



SENSORS



PORTABLE MEASURING ARMS



SERVICES



LASER TRACKERS & STATIONS



MULTISENSOR & OPTICAL SYSTEMS



WHITE LIGHT SCANNERS



METROLOGY SOFTWARE SOLUTIONS



CAD / CAM



STATISTICAL PROCESS CONTROL



AUTOMATED APPLICATIONS



MICROMETERS, CALIPERS AND GAUGES



DESIGN AND COSTING SOFTWARE

m&h Inprocess Messtechnik GmbH

sales.mh@hexagon.com

www.mh-inprocess.com