

m&h PROBING SYSTEMS WITH INFRARED TRANSMISSION

MEASURING ON MACHINE TOOLS





10 Nm max.
1.5 kN max. WWW
mh-inprocess

 **HEXAGON**

FLEXIBLE – MODULAR – READY FOR THE FUTURE

The modular probing system IRP25.50 can be used for a range of applications. It can be easily modified by simply screwing in various measuring units. Extensions and cross-probes can both be used.

The development of further measuring units and sensors which can be used on the same system basis is planned for the future.

- Reliable HDR+ infrared transmission
- ITE technology – pre-positioning with high-speed
- Safe, reliable activation methods
- Up to 1000 hours of continuous use before battery change
- Robust, flexible and future-proof

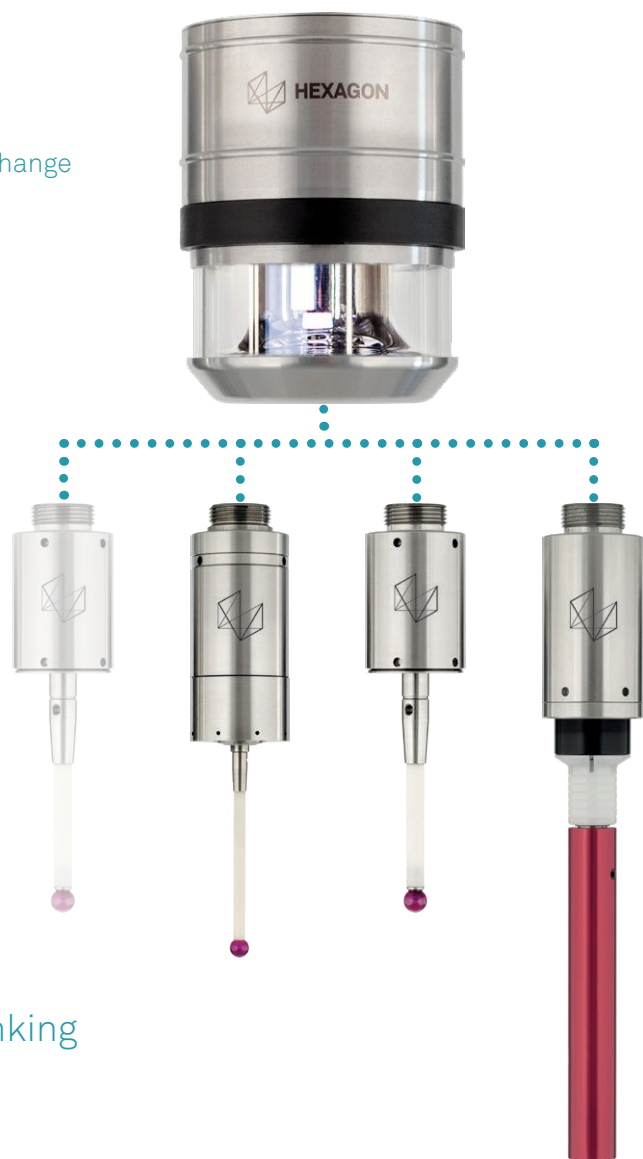

Innovative, customer-oriented thinking
and actions create unparalleled
measuring solutions

MORE THAN JUST FLEXIBLE

m&h offers two measuring units with different operating principles and a temperature measuring units, which ensure uncompromising precision under the harsh conditions in the machine tool.

Your advantage:

- Different measuring units for one system basis
- Cost-effective for various requirements
- Warehousing cost savings thanks to flexibility
- Very well preparation for the future



m&h IRP25.50-PP

The PP version is equipped with the PP41.00 measuring unit with its tripod system. The secure standard for universal use is best suited to the majority of measuring tasks. Cross-probes can be used, as well as setting the trigger force is possible



m&h IRP25.50-MY

The MY version is equipped with the MY21.00 measuring unit with its patented hemisphere system. Its homogeneous probing behaviour makes it especially advisable for machines without rotation spindles.



m&h IRP25.50-TP

The TP version is equipped with the TP44.10 temperature measuring unit with patented temperature measuring technology. The right solution for consistent manufacturing quality or cost-intensive workpieces.



m&h IRR91.50

The bidirectional infrared receiver IRR91.50 is able to simultaneously communicate with three probing systems on the same machine. It processes measurement, temperature and dual probe data. Universally applicable and extremely robust - IP68. There is no additional interface required in the control cabinet.



m&h IRR91.42

IRR91.42 reliably receives measurement and temperature data. It can communicate with m&h infrared probes and infrared tool setters. The receiver can communicate with three different probing systems on the same machine. All necessary components are integrated in the stainless steel housing.

TECHNICAL DATA

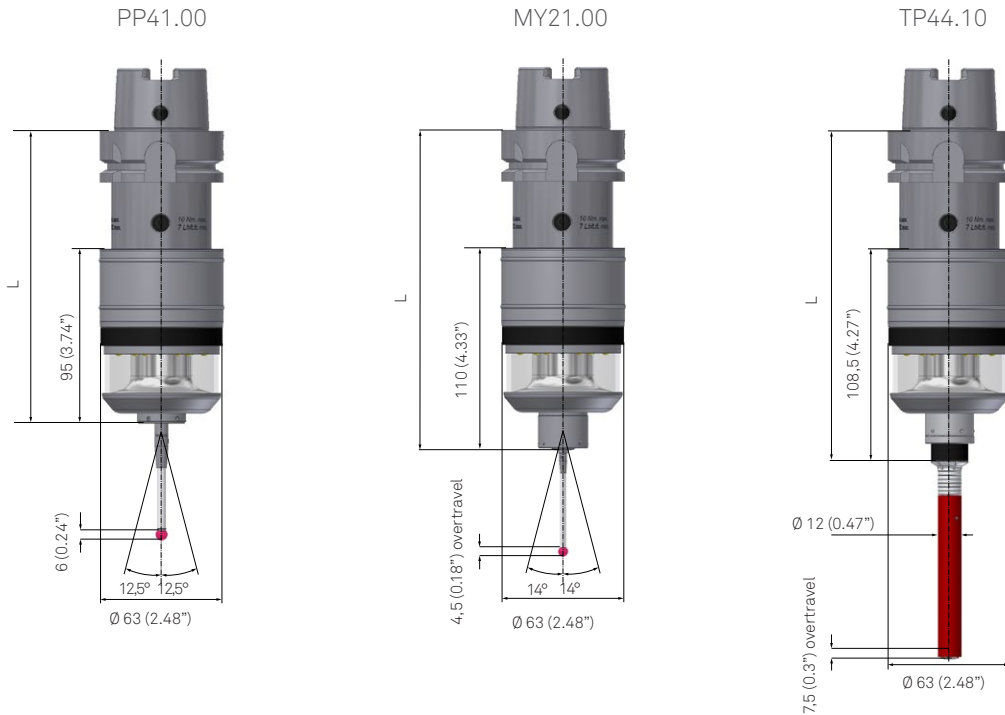

Description		PP41.00 Measuring unit	MY21.00 Measuring unit	TP44.10 Measuring unit
IRP 25.50	Repeatability at probing from one direction	2 Sigma $\leq 1 \mu\text{m}$ with 50mm stylus and 254 mm/min	2 Sigma $\leq 1 \mu\text{m}$ with 50mm stylus and 254 mm/min	-
	Recommended probing feedrates	Max. 2000 mm/min		500 mm/min
	Sensing directions	$\pm X, \pm Y, -Z$		$-Z$
	Maximum stylus overtravel	XY $\pm 12,5^\circ$; Z -6 mm	XY $\pm 14^\circ$; Z -4,5 mm	-6,9 mm
	Trigger force	XY = 0,3 - 1,4 N; Z = 2,5 - 12,5 N (with 50mm stylus)	XY = 1 N; Z = 6 N (with 50mm stylus)	13N (Trigger force with 50mm sensor)
	Extensions $\varnothing 25$ (0.98")	30mm (1.18"), 50mm (1.97"), 100mm (3.94"), 200mm (7.87")		
	Power supply	1 x 9 V battery block, lithium: 1200 mAh, Alkaline: 550 mAh		
	Battery lifetime in continuous operation (Probing every 2 seconds)	Up to 1000 hours		
	Weight without shank	Approx. 920g		
	Temperature range	Storage: 5 °C - 70 °C, Operation: 10 °C - 50 °C		
	Material	Stainless steel		
	Signal transmission	HDR+		
Protection class	IP68: EN60529			

m&h INFRARED RECEIVER

The bidirectional infrared receivers can communicate with several touch probe systems on the same machine simultaneously. They have wide transmission and reception angles and can be used for all m&h infrared touch probes and tool setters. All necessary components are integrated into the stainless steel casing, so there is no additional interface required in the control cabinet.

m&h IRR91.50

- Processes measurement and temperature data
- Available with radial and axial cable outlet
- Dual-probe as well as bidirectional HDR+ Technology
- Can be universally used and is extremely robust – IP68

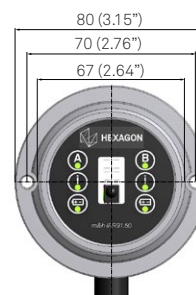

m&h IRR91.42

- Processes measurement and temperature data
- Bidirectional HDR+ Technology
- No additional module or interface in the control cabinet required
- Designed for mounting directly in the headstock – IP68

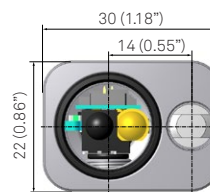

	Description	IRR91.50	IRR91.42
INFRARED-RECEIVER	Signal evaluation	High Data Rate+ (HDR+)	High Data Rate+ (HDR+ and HDR-Bidi (B))
	Power Supply	12 - 23 VDC, max. 100 mA	
	Weight	1450g = IRR91.50-A (with cable) 1550g = IRR91.50-R (with cable and protection tube)	100g
	Temperature range	Operation: 10° - 50°, Storage: 5° - 70°	
	Material	Stainless steel	
	Sealing	IP68: EN60529, IEC529/DIN40050	
	Mounting	2x Cap head screw M5	Air-blow screw M4 thread

FLEXIBLE MEASURING SOLUTIONS IN THE MACHINE TOOL

Latest-generation m&h touch probes offer the widest range of options in the machine tool. Reliability and precision are the key to consistently high quality with optimized processing times. Due to the fact that the IRP25.50 can be used both as a probe as well as a temperature sensor, the warehousing costs for replacement devices are much lower than for separate device types. This is another advantage, particularly in lean production.

m&h touch probes fulfil all requirements in the machine tool in tried and tested fashion. Extreme accelerations, high positioning speeds, constant vibrations, hard tool changes, increased temperatures and coolants pose no problems for m&h touch probes. m&h's precision mechanics can continue to switch without wear and extremely precisely for years under all these conditions.

Robust and durable

- Glass ring to protect the infrared diodes
- Housing made of stainless steel
- All seals made of viton
- Measuring unit protection by means of chip guard plate
- Probe completely sealed (immersion-tight) in acc. with IP68

Fast, safe and precise

- Pre-positioning with high-speed (up to 50 000 mm/min) thanks to ITE technology (Intelligent Trigger Evaluation)
- One-touch strategy for fast, precise probing (up to 2000 mm/min)
- Safe and reliable probe activation methods

Workshop-oriented handling

- Very easy handling and setting by the operator
- Fast battery change (standard batteries) without tools
- Easy stylus change and runout adjustment

PRODUCTIVITY IN SERIES PRODUCTION

The high productivity in series production requires flexible and effective measurement solutions. As an experienced supplier in the measuring technology area for machine tools, integrating the current requirements of our customers into our developments is among our core competences.

m&h dual-probe technology

Dual-probe technology allows simultaneous measurements on both spindles of double-spindle machines having two m&h IRP25.50s and one m&h IRR91.50. Compared to a solution with radio probes, they are much less expensive and easier to use. Furthermore, the cycle times are reduced.

m&h IRP25.50-TP

Measures fully automatically the workpiece temperature both before as well as during machining (patented). This allows the control of production processes and the adaptation of machining parameters during production. This way, temperature-dependent parameters can be reliably determined before the workpiece goes to the next machining step with tolerance specifications. This way, consistently high production quality is ensured.



PATENTED TECHNOLOGY

m&h Temperature sensor

Fully automatic workpiece temperature detection.

m&h Dual-Probe technology

Simultaneous measurement of two IRP25.50s with just one IRR91.50 receiver.

m&h Activation Methods

Pullstuds and water activated switches.

HSK Shanks with Thermo-Lock® technology

Prevents heat expansion of the shank to the probe body.

m&h Tool Setter with adjustable positions

Fast changeover to a pre-mounted, magnetic base plate.

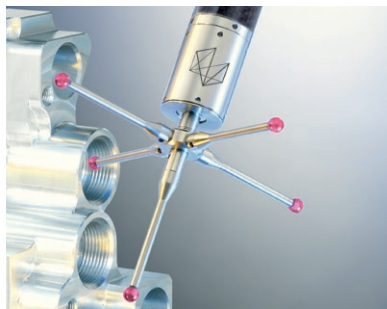
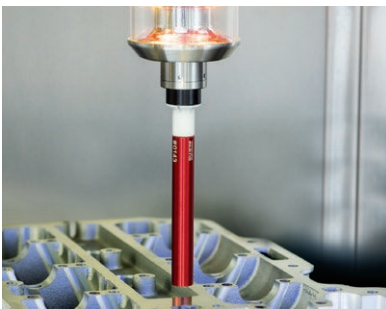
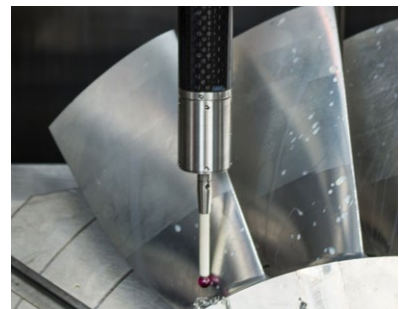
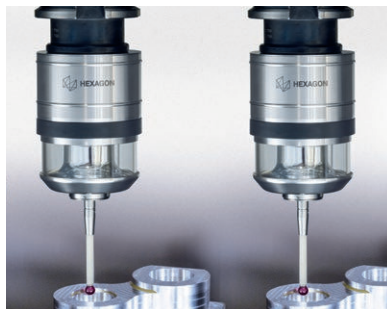
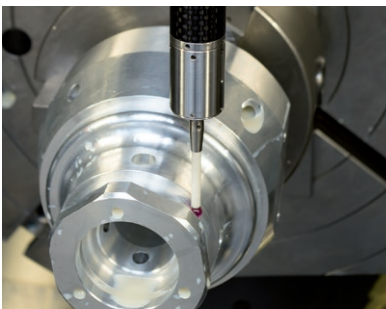

STATE-OF-THE-ART

HDR⁺-infrared transmission

The new IRP25.50 uses the improved HDR⁺ infrared transmission (High Data Rate⁺). This guarantees that only the system's own signals are processed. Disturbances caused by extraneous light are ruled out. The HDR⁺ transmission ensures the bidirectional signal transmission between the receiver and probe with a homogeneous directional characteristic over reflecting surfaces. In addition, without loss of process reliability, transmission power was increased and energy consumption optimised. This enables a battery lifetime of up to 1000 hours in continuous operation.

ITE technology

The m&h IRP25.50 with ITE technology (Intelligent Trigger Evaluation) allows you to pre-position at high speed (up to 50 000 mm/min). Fast and precise probing (up to 2000 mm/min) through the m&h one-touch strategy makes maximum precision possible. This means that the m&h infrared probe IRP25.50 moves at top speed to the measuring point, so that it can reliably probe at constant measuring speed with only one touch. This considerably accelerates the measuring process and saves valuable production time.

Enhanced activation options

In addition to the proven, reliable mechanical activation options, the m&h IRP25.50 also offers the option of bidirectional activation. This is done using separately coded signals and is therefore not inferior to mechanical methods with regard to reliability.

- Patented pullstud activation
- Patented water-switch activation
- Mechanical HSK activation
- Separately coded ON/OFF infrared activation

m&h Chameleon technology

- Supports third-party protocols of competitors
- Easy and inexpensive alternative in case of a probe crash
- Simple protocol setting
- No conversion required when changing to m&h

COMPACT AND BIDIRECTIONAL FOR VARIOUS APPLICATIONS

m&h has three other infrared touch probes with different operating principles for different applications and machine sizes, as well as a manually changeable infrared touch probe system, which can be used alongside any infrared touch probe.



m&h IRP40.02

Mass production places the highest demands on the manufacturing process. Extreme accelerations, high positioning speeds, constant vibrations, hard tool changes, increased temperatures and aggressive coolants pose no problems for IRP40.02 touch probes. m&h's precision mechanics can continue to switch without wear and extremely precisely for years under all these conditions

- Reliable HDR+ infrared transmission
- Short measurement times thanks to intelligent trigger evaluation (ITE) technology and one-touch strategy
- HSK shanks with THERMO-LOCK® Technology
- Up to 800 hours of continuous use before battery change



m&h IRP40.40-LF

Specially developed for delicate materials and measuring tasks on thin, fragile workpiece geometries. The measuring unit, with constant very low trigger forces, can be fitted with different styli and spherical measuring tips from $\varnothing 0.2$ mm. Even at higher probing velocity and greater stylus deflection the probing forces on the m&h IRP40.40-LF remain constantly low – this characteristic protects your delicate, highly sensitive workpieces against damage.

- Constant, minimum probing forces
- Reliable HDR infrared transmission
- HSK shanks with THERMO-LOCK® Technology

THERMO-LOCK® TECHNOLOGY

- Prevents heat transfer from the spindle to the probe
- Eliminates uncontrolled expansion of the shank and probe body
- HSK shanks with THERMO-LOCK® technology are available in various sizes

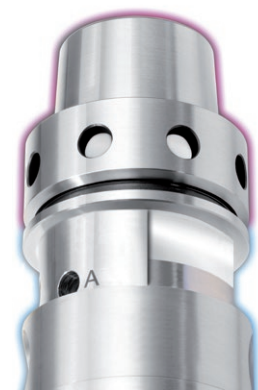

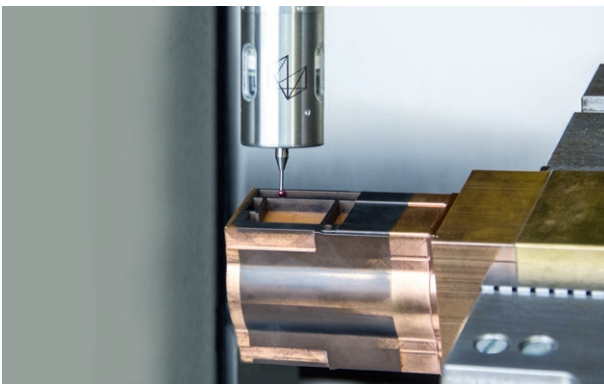

m&h IRP40.50

The ultrasmall infrared probe with a diameter of only 25 millimeters and a length of 42.4 millimeters, can find a place in any small machining center and leaves sufficient space so that measurement is also possible on the Z axis without a danger of collision. The IRP40.50 is highly precise and is also suitable for small and delicate workpieces with a low probing force of 1,3 N (X/Y).

- The smallest infrared probe in the world
- Reliable bidirectional HDR infrared transmission
- Energy-efficient and economical



m&h IRT35.70

The Infrared Tool Setter for milling machines and machining centers enables variable positioning of the tool setter, to fit the task at hand. Through use of a magnetic mount, the tool setter can be placed in wide range of table positions. Our patent pending system delivers highly accurate and repeatable re-positioning of the tool setter. No cumbersome cables or other hardware outlines encroach on the machining area. Tool measurement as well as tool breakage controls can be carried out flexibly with only one device.

- Quickly mounted on pre-mounted base plate
- Wireless, removable, no lost machining area
- Can be shared between machines

TECHNICAL DATA

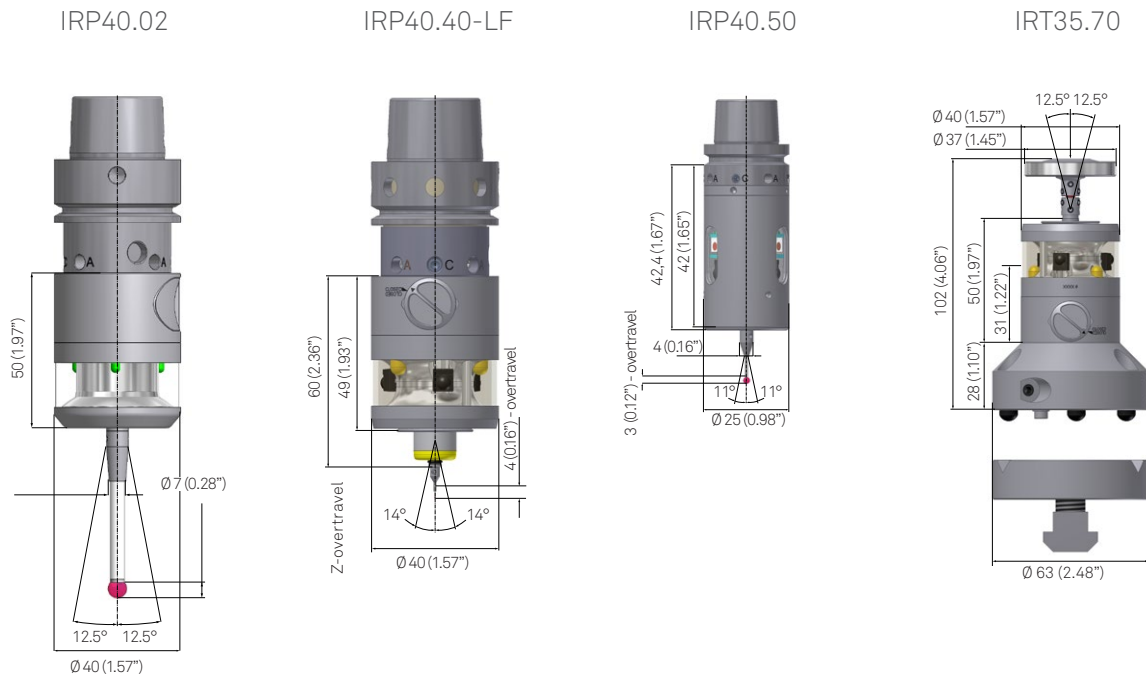

	IRP40.02	IRP40.40-LF	IRP40.50	IRT35.70	
OVERVIEW	Description	IRP40.02	IRP40.40-LF	IRP40.50	IRT35.70
	Repeatability at Probing from one direction	2 Sigma $\leq 0.5 \mu\text{m}$ with 50mm Stylus and 254mm/min	2 Sigma $\leq 1 \mu\text{m}$ with 20mm Stylus and 254mm/min	2 Sigma $\leq 1 \mu\text{m}$	2 Sigma $\leq 1 \mu\text{m}$ at 100mm/min
	Probing directions	$\pm X, \pm Y, -Z$			
	Max. stylus deflection	X/Y $\pm 12.5^\circ$; Z -5 mm	X/Y $\pm 14^\circ$; Z -4 mm	X/Y $\pm 11^\circ$; Z = -3 mm	X/Y $\pm 12.5^\circ$; Z -5 mm
	Trigger force	X/Y = 0.8 N, Z = 5.7N	X/Y = 0.08 N, Z = 0,8 N	X/Y = 1,3 N, Z = 3 N	X/Y = 2 N, Z = 8 N
	Recommended probing	Max. 2000 mm/min	Max. 480 mm/min	Max. 2000 mm/min	-
	Power supply	Batterie 2 x 3,6 V ½AA	Batterie 1 x 3,6 V ½AA	3 x 3 V Batterie, Typ CR2032	Batterie 1 x 3,6 V ½AA
	Battery lifetime	Up to 800h in continuous use	Up to 440h in continuous use	Up to 400h in continuous use	-
	Weight without shank	Ca. 390 g	Ca. 240 g	Ca. 78 g	Ca. 750 g (without base plate)
	Material	Stainless steel	Stainless steel	Stainless steel, polyamide	Stainless steel
Protection class	IP68: EN60529				
Temperature range	Operation: 10° – 50°C, Storage: 5° – 70°				

Smallest tool for length measurement at probing speed 100 mm/min $\varnothing 0,05 \text{ mm}$ (0.02")

CUSTOMER STORIES

m&h's high-quality measurement systems are specially designed and made for use in machines tools, impressing with their maximum precision and reliability. Here are extracts from testimonials by users of m&h probing systems with infrared transmission

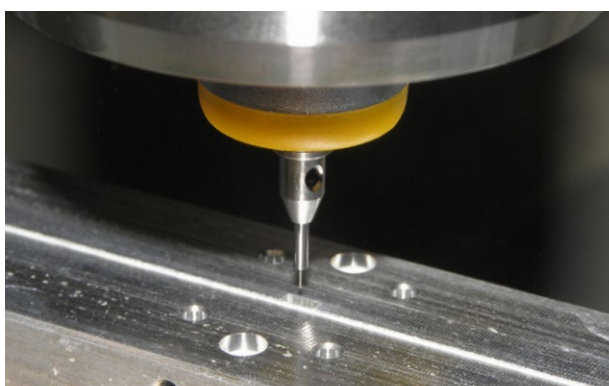

Feinmechanik Leipold, Blechhammer, Germany

Using styli with very small tooling balls from 0.2 mm in diameter means that even the smallest of contours can be measured with the lowest possible measuring force.

m&h's patented THERMO-LOCK® technology prevents heat expansion. And Leipold has noticed something else: "we no longer have any deviation along the Z axis".

This is due to the fact that the IRP40.40-LF touch probe purchased is the THERMO-LOCK® version. This technology, patented by m&h, prevents heat expansion of the shank to the probe body or measuring unit.

“More accuracy, less reworking and gains in production time thanks to m&h touch probes”

enthuses Fredi Leipold.

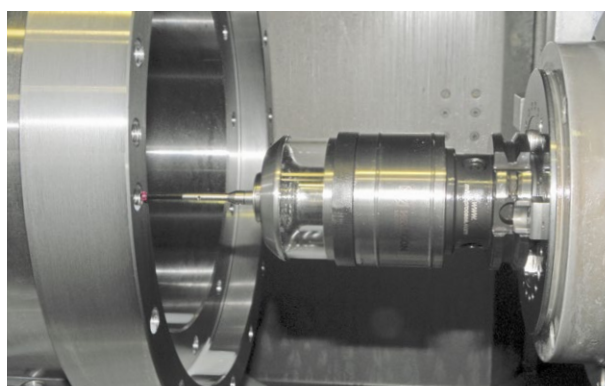

Werkzeug- und Maschinenfabrik, Ray AG, Nänikon, Switzerland

The device boasts excellent signal emission as the transmitter diodes are arranged in such a way that their signals are reflected on polished surfaces and emitted consistently. Yet toughened glass protects these diodes from the effects of all coolant and chips. Everything is sealed to IP68 standard, so pressure of up to one metre of water depth.

“After our negative experiences with other products, this was a decisive factor for us”

explains Andi Baumann.













HEXAGON

MANUFACTURING INTELLIGENCE

Hexagon Manufacturing Intelligence helps industrial manufacturers develop the disruptive technologies of today and the life-changing products of tomorrow. As a leading metrology and manufacturing solution specialist, our expertise in sensing, thinking and acting – the collection, analysis and active use of measurement data – gives our customers the confidence to increase production speed and accelerate productivity while enhancing product quality.

Through a network of local service centres, production facilities and commercial operations across five continents, we are shaping smart change in manufacturing to build a world where quality drives productivity. For more information, visit HexagonMI.com.

Hexagon Manufacturing Intelligence is part of Hexagon (Nasdaq Stockholm: HEXA B; hexagon.com), a leading global provider of information technologies that drive quality and productivity across geospatial and industrial enterprise applications.

-  COORDINATE MEASURING MACHINES
-  3D LASER SCANNING
-  SENSORS
-  PORTABLE MEASURING ARMS
-  SERVICES
-  LASER TRACKERS & STATIONS
-  MULTISENSOR & OPTICAL SYSTEMS
-  WHITE LIGHT SCANNERS
-  METROLOGY SOFTWARE SOLUTIONS
-  CAD / CAM
-  STATISTICAL PROCESS CONTROL
-  AUTOMATED APPLICATIONS
-  MICROMETERS, CALIPERS AND GAUGES
-  DESIGN AND COSTING SOFTWARE

m&h Inprocess Messtechnik GmbH

sales.mh@hexagon.com

www.mh-inprocess.com