



Maschinenfabrik  
**FRÖMAG**

This is  
**HOW WE DO IT.**



FRÖMAG develops and manufactures CNC-machines for keyseating, profiling and broaching in Fröndenberg / Ruhr, Germany.

Our machines are designed for simple installation and setup and are highly efficient, proven by machines working reliably for 50 years and more. This underlines our high level of commitment to quality.



# CONTENT

---

Maschinenfabrik FRÖMAG	4
Sustainability	6
Competence	9
Service	10
Broaching	11
Keyseating and Profiling	18
Indexing Tables	24
Remote Service Support	26
Interface	29
Retrofit	30
Individual Solutions	33
Control Unit	34
Automation	35
Subcontracting	37
Tools	39

# Maschinenfabrik **FRÖMAG**

---

## We build the future

Innovation, quality and sustainability are standards that reflect and define our company.

Product innovation is achieved by the continuous advancement of our product range and integrating new solutions for trendsetting industrial processes.

Sustainability is not just the result of innovation and quality, it is a FRÖMAG design principle. Even during the development of new products, we pay attention to resource conservation and environmentally friendly production. This includes minimizing emissions and energy consumption, as well as using environmentally compatible manufacturing processes.

We are a midsize family-owned company. Our actions are driven by medium and long-term objectives. The competence and experience of our employees build the important foundation for operating successfully in the market. Therefore, we place great emphasis on training and staff promotion.





## Innovation

Each FRÖMAG machine is based on more than half a century of experience. This experience is based on constant innovation. Only those who constantly drive new developments can make something good even better.



## Quality

In order to meet the highest demands of our customers, there is only one mission for FRÖMAG: Quality. This is and will remain our credo, to which we are committed.



## Efficiency

The legendary FRÖMAG economic efficiency is achieved by electromechanical drives, short setup times, high energy efficiency, user-friendly operation, and the highest precision.

# SUSTAINABILITY

---

Sustainability is at the heart of our corporate philosophy. We are fully aware of our responsibility towards the environment and future generations to come. Therefore, we have taken a variety of measures to reduce our ecological footprint.

One focus is on promoting energy efficiency. To achieve this goal, we have converted our lighting systems to innovative, energy-efficient solutions. In addition, we rely on environmentally friendly packaging and increasingly incorporating renewable resources into our resources in our production processes.

Another important step was the recording of the greenhouse gas emissions caused by our business activities. To offset these emissions, we have purchased climate protection certificates for the years 2023 and 2024. This shows our determination and commitment to make a positive contribution to reducing global warming.

Our products reflect our long-term commitment to sustainability and environmental protection. For some time now, we have deliberately opted for servo drive technology instead of hydraulic solutions. By using servo drives, we reduce the energy consumption of our products and thus also our CO2 emissions. Furthermore, this technology leads to a more efficient use of resources and replaces the need for hydraulic fluids.

You, our customers, not only benefit from the improved performance and precision of our products, but also actively contribute to reducing the environmental impact.

We pride ourselves on implementing sustainable practices in all of our business operations. Our goal is to ensure a sustainable future for generations to come and to actively contribute to the protection of the environment as a responsible company.

Together we can create  
a sustainable future!



SERVO  
DRIVE

REMOTE  
SUPPORT

MADE IN  
GERMANY

- ✓ Energy-saving servo drives
- ✓ Up to 50 % energy savings compared to hydraulic drives
- ✓ Retrofit for resource-saving life cycle extension
- ✓ Remote maintenance ready





**We know what we install  
in our machines, so in the  
end we can say with pride:  
"when quality goes in,  
quality comes out".**



# Our **COMPETENCE**

---

Around the world roughly 6.000 FRÖMAG machines are valued for their outstanding quality, reliability and efficiency, delivering cost saving solutions in many areas:

- Drive technology  
(motors, gear mechanisms, couplings)
- Pump, fitting and machine construction
- Materials handling, conveyor technology and wind energy
- Automation and components
- Individual solutions for other applications

State of the art machinery and equipment along with highly qualified personnel support a high degree of vertical integration.

FRÖMAG is represented in the US market by the subsidiary Mitts & Merrill.

## What sets FRÖMAG machines apart

- Short setup times
- User-friendly operation
- Optimum working height
- Highest accuracy
- Rigid, solid design
- Electromechanical drives
- Energy efficient

# Our **SERVICE**

---

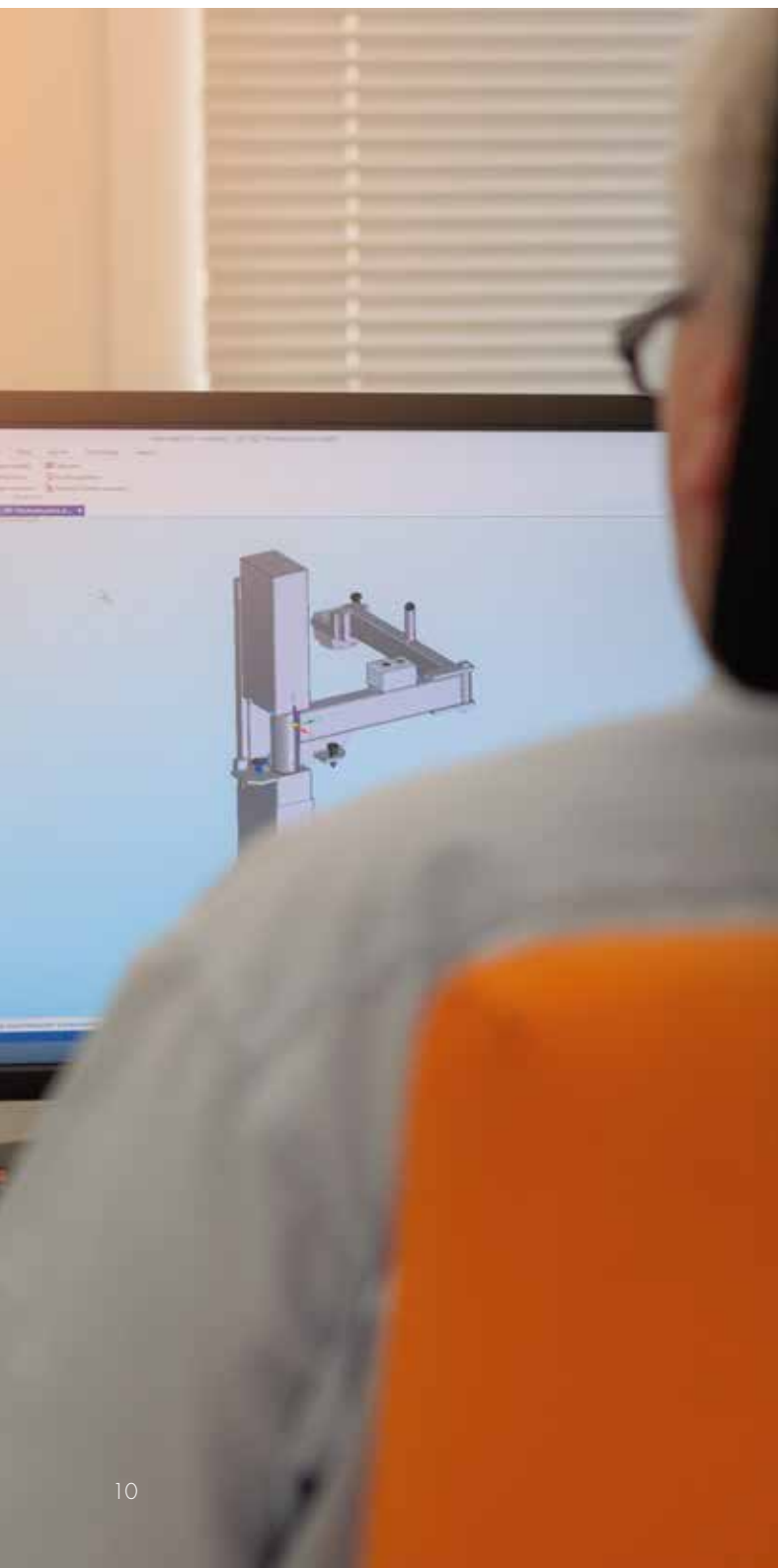

Our team of experts is available to help you with everything from procurement to commissioning and maintenance.

Increasing productivity, assuring quality, improving efficiency and satisfied customers are our main objective.

Our extensive service offered to our customers includes:

- Advice during procurement process
- Commissioning
- Maintenance and repair
- Training of staff
- Tool selection and setup
- FRÖMAG refurbishment & retrofit

A close-up photograph of a brass broaching tool, showing its textured, cylindrical surface. The tool is positioned diagonally across the frame. The background is blurred, showing other mechanical components. An orange rectangular overlay is present at the bottom of the image, containing the title text.

# Electromechanical Table Up Broaching Machines

# BROACHING

---

Broaching is a machining process using a single cutter bar with multiple graduated cutting edges, in which the broaching tool is moving relative to the workpiece. The material to be machined is removed in one stroke preferably. Because of the stepped shape of the broaching tool there is no need for an infeed motion. Broaching is principally used in cases in which complex and difficult to manufacture profiles of high surface quality, high rigidity, and precision are needed.



## FRÖMAG Table-Up Broaching-Machines

While developing the electromechanical Table Up machines FRÖMAG emphasized improving the profile accuracy of the workpieces to be processed by using electromechanical drives with a highly linear behavior. Compared to hydraulically driven machines the energy efficiency is vastly improved. Further advantages are the omission of hydraulic power packs, cooling units, and oil pans, which leads to less space requirements and more safety because no oil leaks can occur.

The energy consumption is reduced, since the energy is only needed for machine movements and not to maintain a constant oil pressure. A constant chip flow will be achieved due of the inherent rigidity of the electromechanical drives, leading to an improved broaching result.

FRÖMAG electromechanical driven FTR broaching machines ensure cost effectiveness and efficiency.

Due to the ergonomic construction, the machines can be placed at ground level and do not need a foundation pit. They can be operated without additional platforms or pedestals.

The FTR broaching machines can be set up as stand-alone machines with either manual or automated feed. They can also be fully integrated into machining cells applying robotics and handling devices. Contrary to conventional broaching machines the broaching tool stays stationary and the moving table including the workpiece and workpiece clamping is moved relative to the broaching tool.

The FRÖMAG Table Up broaching machines consist principally of the following components: the broaching machine itself, the control cabinet, and the chip conveyor, which can be assembled on each side or the back face of the machine.

The base of the FRÖMAG Table Up Machine is manufactured as a durable weldment that is also the broaching oil or emulsion reservoir. Between the frames on the left and the right side of the machine, the combined moving and sliding table is driven by two ball splines. The machine is equipped with a central lubrication system. The filling level is monitored by the control software.

Below the moving table a shaftholder either for broaching tools according to DIN 1417 or DIN 1415 is mounted onto a rigid cross member.

Also, a retriever system for lifting the broaching tools is implemented into the machine. This system is operating above the moving table. During the initial broaching process the retriever system yields additional stability to the broaching tool.

FRÖMAG Table Up broaching machines are designed to accomplish highest machining quality. Therefore FRÖMAG only uses high value components.



*FTR series with control cabinet*

# The technical principle **BROACHING**

---

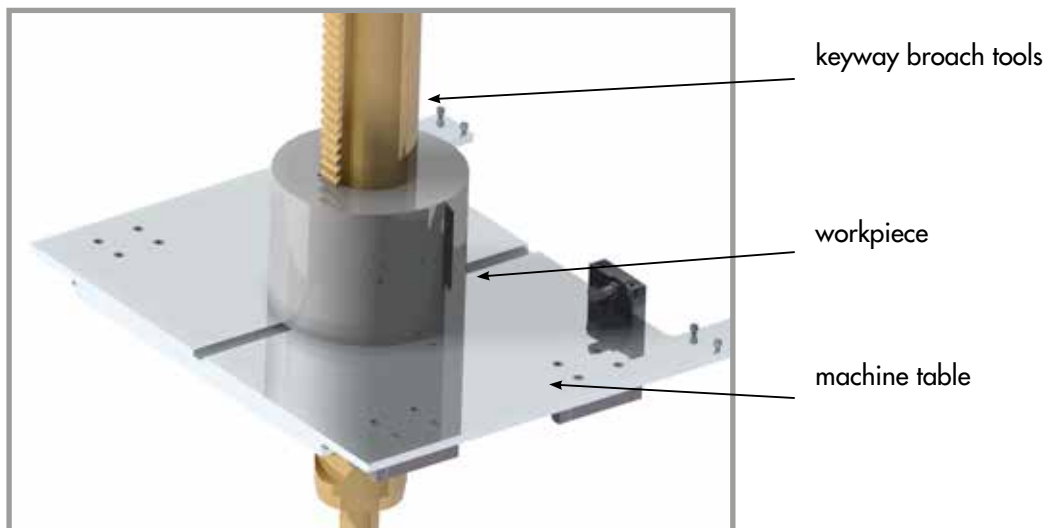
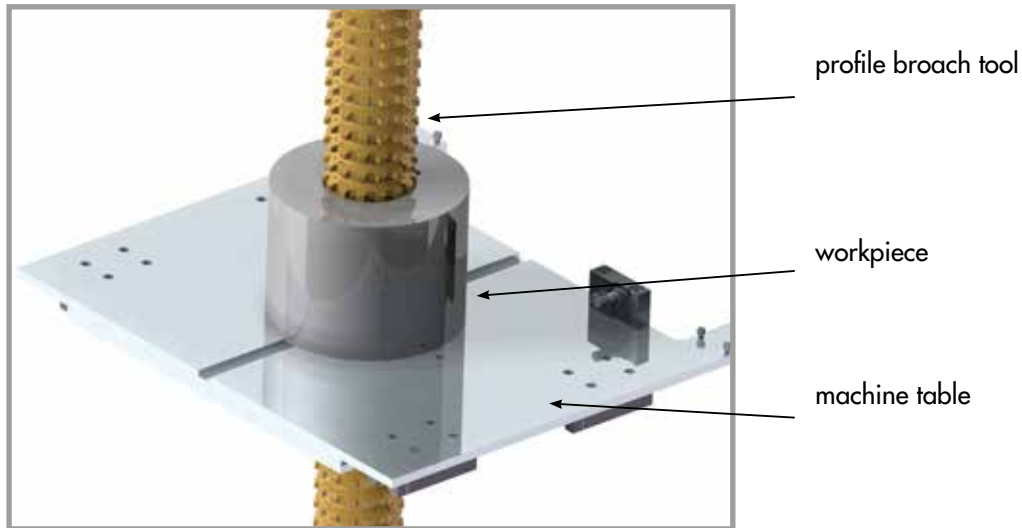

## Workpiece samples

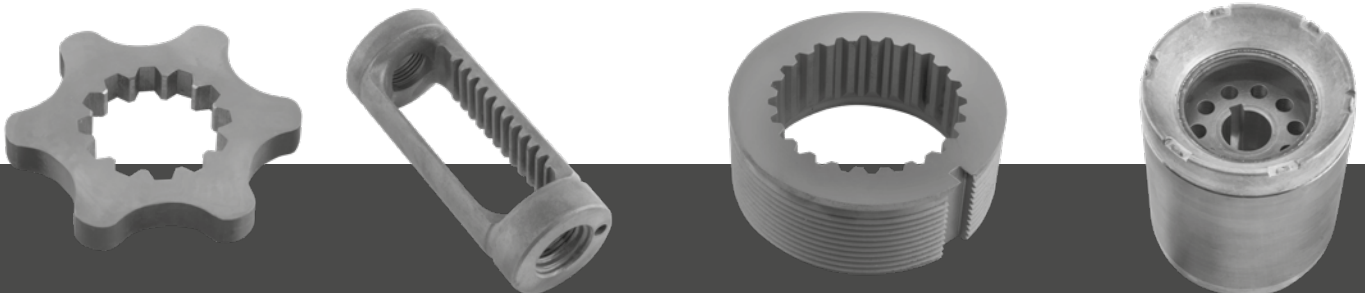

## Broaching machine Type FTR

Broaching machines of the FTR-Series feature a moving table design so that no pit for machine installation is required.

Therefore the machine can be placed at ground level and is easy accessible due to its sliding doors.

The compact design offers numerous options for integration into your production lines, with e.g. robots or handling-systems.

### Highlights:

- Installable at ground level
- Ergonomic design
- Highly productive
- Economic
- Space saving
- Versatile
- Fully automatic operating cycle
- Remote support interface

### Options

- Automation
- Side loading in addition to the front door from left, right, or left and right
- Machine data via OPC-UA
- RFID Tagreader



*FTR series for ground level setup*

### Features and dimensions FTR

Machine type	Stroke (mm)	Pulling force (kN)	Connected load (KW)	Height of the machine table (mm)	Total height (mm)	Basic dimensions B x L (mm)
FTR6-01	1000 1250	60 kN (6 t)	25 KW	940 mm	3060 3360	1700 x 1230
FTR9-01	1000 1250	90 kN (9 t)	30 KW	940 mm	3060 3360	1700 x 1230
FTR10-11	1500 2000	100 kN (10 t)	30 KW	1060 mm	4100 4600	2100 x 1430
FTR20-11	1500 2000	200 kN (20 t)	55 KW	1060 mm	4100 4600	2100 x 1430
FTR30-11	1500 2000	300 kN (30 t)	80 KW	1140 mm	4100 4600	2520 x 1600

## Broaching machine Type FSR

FRÖMAG electromechanical vertical internal broaching machines FSR, guarantee high efficiency and low production cost due to their special design. The pull bridge of the machine is designed to accept broach holders according to different standards. Ball screws used for the stroke movement of the pull bridge as well as the additional hardened and ground guide columns, result in a connection with the Servo-motors for a smooth and rigid running performance of the machine.

Additional equipment offered such as the retriever, shim control, and moveable table, ease machine operation and facilitate automatic machine performance as well as the use of machines in transfer lines.

### Options

- Automation
- Side loading in addition to the front door from left, right, or left and right
- Machine data via OPC-UA
- RFID Tagreader

### Highlights:

- Highly productive
- Economic
- Space saving
- Versatile
- Fully automatic operating cycle
- Remote support interface



Type: FSR-RST

Type: FSR-MZ

### Features and dimensions FSR

Machine type	Stroke (mm)	Pulling force (kN)	Connected load (KW)	Height of the machine table (mm)	Total height incl. MZ (mm)	Basic dimensions B x L (mm)
FSR6	800	60 kN (6 t)	15 KW	1830	3770	900 x 1040
	1000			2060	4270	
	1250			2310	4770	
FSR9	1000	90 kN (9 t)	25 KW	2060	4270	
	1250			2310	4770	
	1500			2560	5270	
FSR18	1000	180 kN (18 t)	40 KW	2060	4270	1320 x 1410
	1250			2310	4770	
	1500			2560	5270	
	2000			3060	5770	
FSR28	1250	280 kN (28 t)	60 KW	2515	4470	1320 x 1410
	1500			2765	4970	
	1750			3015	5470	
	2000			3265	5970	



# Automation

## EXAMPLES

---

Complete manufacturing cell including the supply and discharge belt, stations for deburring and cleaning of the workpieces, suction, side stream cooling, semi-automatic tool change aid and 6-axis robot for flexible parts feeding.

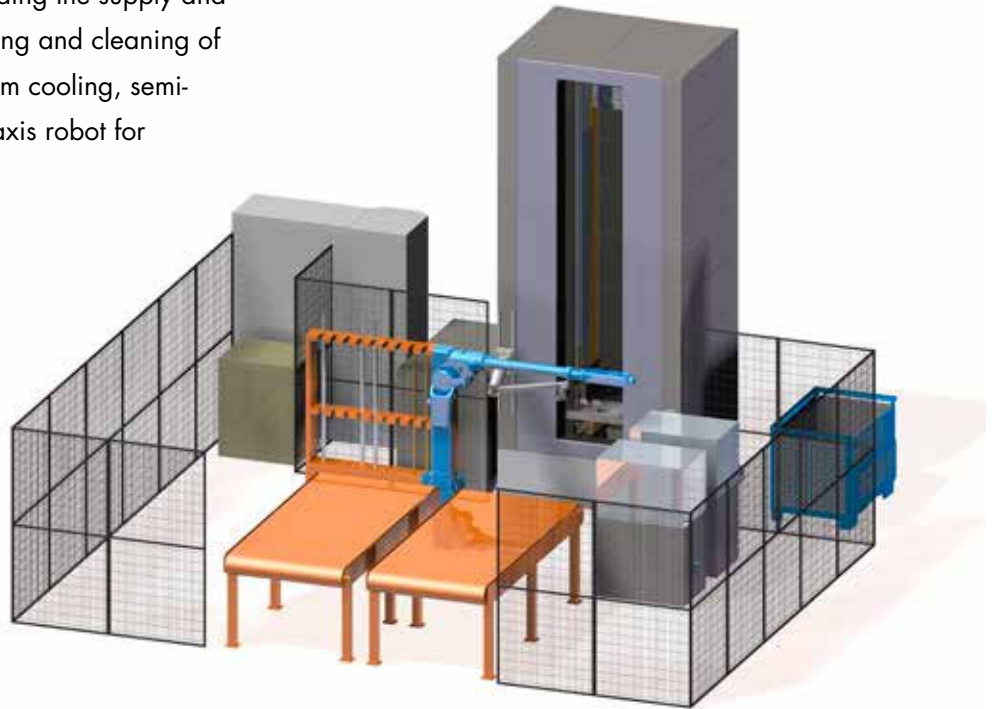

Feeding a FTR20-1500-APC2 by side built servo linear axes. Variable placement of 1-3 broaching locations. Supply via a timed conveyor, storage in bulk containers.

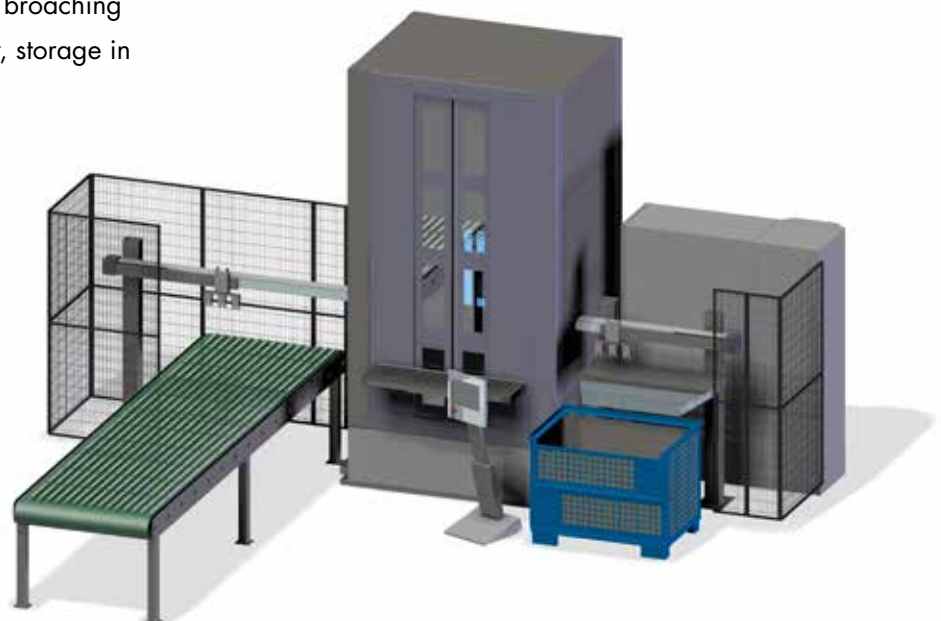



Electromechanical  
Keyseating and  
Profiling Machines

# KEYSEATING

---

Keyseating is a cutting manufacturing process. Grooves for wedges and feather keys are applied into bores of workpieces. Also internal profiles and contours can be cut. The cutting tool is a single edged cutter. It has the width of the required groove or the shape of the required profile. Every groove or profile is made in a multitude of vertical cutting strokes. Because of the low expenses for the cutting tools, keyseating is suitable for single-item production and batch production.



The FRÖMAG keyseating and profiling machines of the Rapida series are designed for high dynamic machining processes due to their improved robustness. They are equipped with a 15" touch screen monitor and a user interface for intuitive operation. Both the stroke and the infeed motion are guided via high-precision ball splines and linear guidings. This leads to a high smoothness and stiffness in the machine movements.

The position is measured by absolute encoders integrated into the servo motor.

The coupling between the motors and the ball screws is made via toothed belts. The operation of the FRÖMAG keyseating and profiling machines is realized by an easy to understand graphical user interface. The texts in this interface are available in every national language.

# The technical principle

## **KEYSEATING**

---

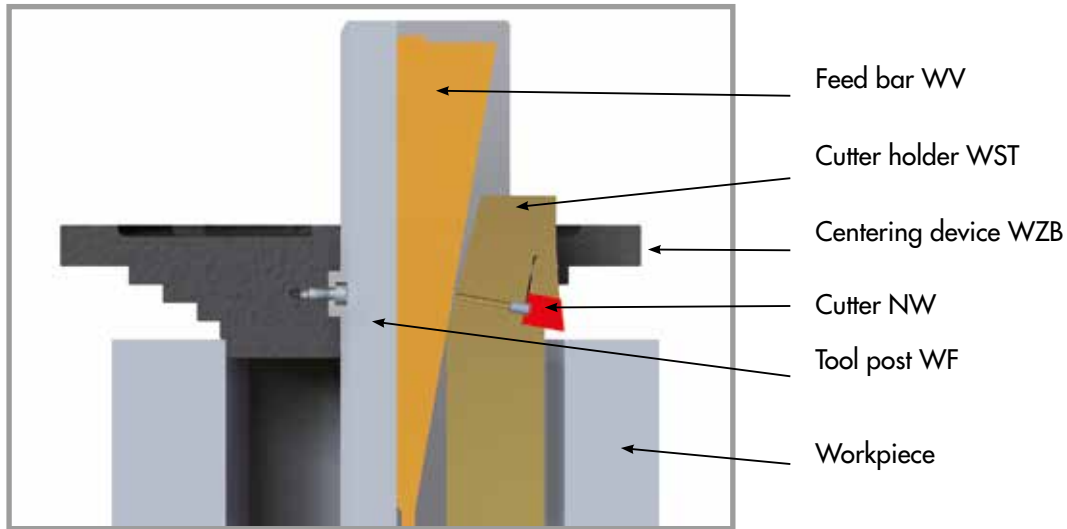

The technical principle slotting with guided tool

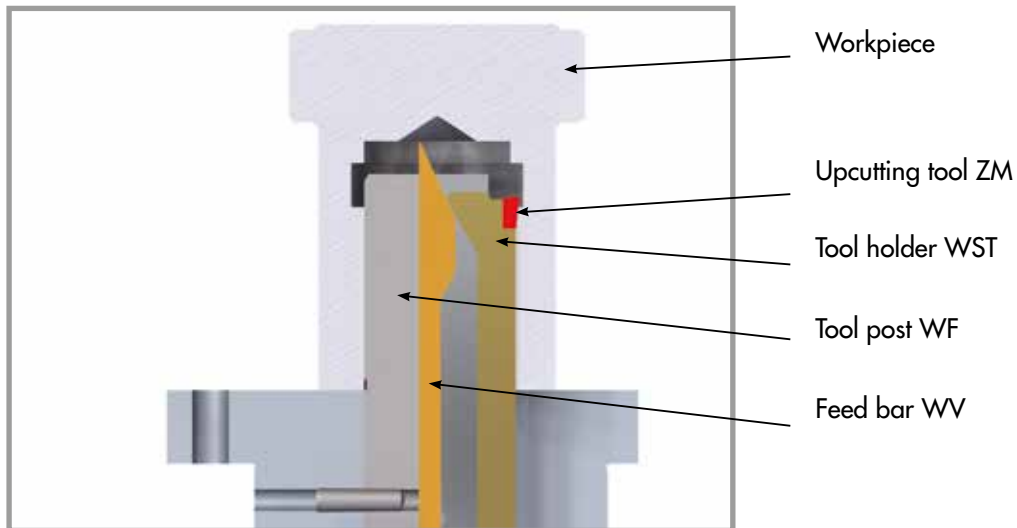

Workpiece samples

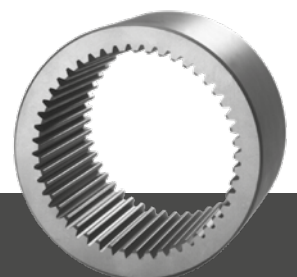
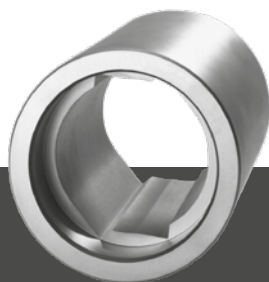

## Advantages of eletromechanical keyseating and profiling machines

- High dynamic behaviour of the stroke and infeed axis, leading to fast movements and precision reversals
- Rigid, heavy-duty backlash and maintenance free precision roller guided in all axis
- High machining precision
- The FRÖMAG Rapida series is placed on ground level in stroke length 425 mm and optionally for 600 mm
- Low space requirement due to compact design without additional hydraulic unit
- No hydraulic oil and costs for maintenance, servicing, oil change, storage and disposal
- No thermal pollution of the environment by the hydraulic unit
- Simple mechanical design
- Low noise emission
- Energy saving
- Position detection in the drive motors
- Easy maintenance and service
- Energy efficient work, since the driving power is accessed only when needed
- Higher efficiency than hydraulic machines
- Stable running characteristics
- High precision stroke and infeed
- Low noise emission
- No risk of leakage in the hydraulic system, no filter change
- Maintenance-free, temperature-independent operation
- No heating of the system by hydraulic flow losses
- Remote Service via fixed network or optional mobile network

The innovative FRÖMAG electro-mechanical keyseating and profiling machines work with the highest quality and excellent efficiency.



Rapida E 32-3-425-1-APC2

## Rapida E

The innovative FRÖMAG electromechanical keyseating and profiling machines work with the highest quality, and with excellent efficiency using high dynamic servo-drives.

- Very high dynamic behaviour of the stroke and infeed axis, leading to fast movements and precision reversals
- Low overall height for keyway lengths up to 600 mm
- Low space requirement due to compact design without additional hydraulic unit
- No hydraulic oil or costs for maintenance, servicing, oil change, storage and disposal
- Extended tool life and improved surface finish due to high running smoothness
- Low thermal and noise emission
- No separate position detection, as it's already included in servo-drives

- Intuitive control with 15-inch display, available in a large number of languages
- Workpiece recognition, no contact, no manual measuring, no additional entries required in the control
- Benefit of the FRÖMAG clamping system: FRÖMAG clamping systems feature a variable height setting in the equipment in order to react flexibly to the vast variety of workpieces.
- Remote support interface

### Options

- Automation
- Interlinking
- Clamping bridge
- Indexing tables
- Machine data via OPC-UA
- RFID Tagreader



Rapida E series

### Features and dimensions Rapida E 32-3/50-3/70-3

	E 32-3	E 50-3	E 70-3
Keyway width (mm)	2 – 32	2 – 50	2 – 70
Keyway length (mm)	425/600	425/600	425/600
Bore size	10 – 130	10 – 230	10 – 500
Cutting- and Return Speed (m/min)	0 – 15 0 – 30	0 – 15 0 – 30	0 – 15 0 – 30
Infeed rate/stroke (mm)	0,01 – 1,5	0,01 – 1,5	0,01 – 1,5
Loading Capacity (kN)	300	350	350
Machine dimensions (mm)			
H	1290	1290	1310
L	1100	1100	1100
B	930	930	930
Stroke 600 FT	250	250	250
Machine Table Size L1 x B1 (mm)	640 x 600	640 x 600	780 x 600
Connected Load (KW)	5,5 KW	7,5 KW	11 KW

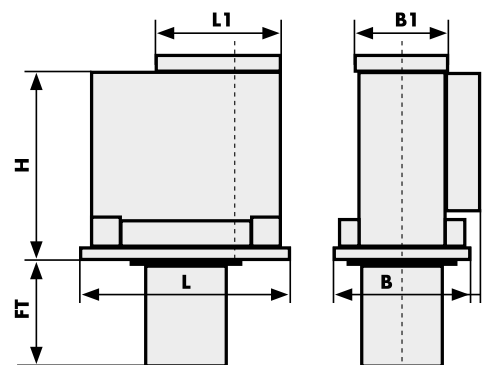

FT = Foundation depth

\*FT for machines with stroke 600 mm

## Rapida CNCE

Additional features compared to Rapida E

- Contoured keyways fully programmable
- Helical keyways
- Tool retraction
- Benefit of the FRÖMAG clamping system:  
FRÖMAG clamping systems feature a variable height setting in the equipment in order to react flexibly to the vast variety of workpieces.
- Remote support interface



Rapida CNCE-series

### Options

- Automation
- Interlinking
- Clamping bridge
- Indexing tables
- Machine data via OPC-UA
- RFID Tagreader

### Features and dimensions Rapida CNCE

		CNCE 70	CNCE 100	CNCE 125	CNCE 150/200
Keyway width (mm)		2 – 70	2 – 100	2 – 125	2 – 150 2 – 200
Keyway length (mm) NL		600/750/1000 1250/1500	600/750/1000 1250/1500	600/750/1000 1250/1500	1000/1250/1500/ 1800/2000
Bore size		10 – 500	10 – 500	10 – 500	20 – 750
Cutting- and Return Speed (m/min)		0 – 38	0 – 38	0 – 38	0 – 38
Infeed rate/stroke (mm)		0,01 – 2	0,01 – 2	0,01 – 2	0,01 – 2
Loading Capacity (kN)		300	350	350	400
Machine dimensions (mm)	H	1290	1290	1290	1305
	L	1285	1285	1285	2135
	B	810	810	810	1115
Machine Table Size L1 x B1 (mm)		800 x 600	800 x 600	800 x 600	2100 x 900

Subject to change without notice

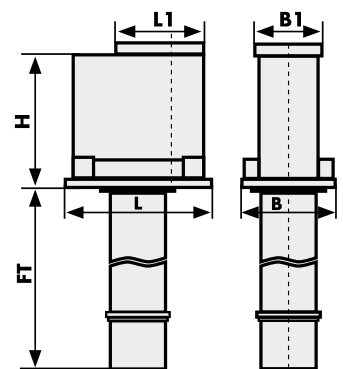

\*FT for machines with stroke 600 mm

Keyway length	Foundation depth
600	595
750	745
1000	995
1250	1245
1500	1495
1800	2650
2000	2850

All dimensions in mm

# Indexing **TABLES**

---

Indexing tables are used for the production of multi-spline profiles according to DIN 5462/72 as well as all other pitches in the production of internal gears, keyways on cover etc. The type designation indicates the throughput of the rotary table.

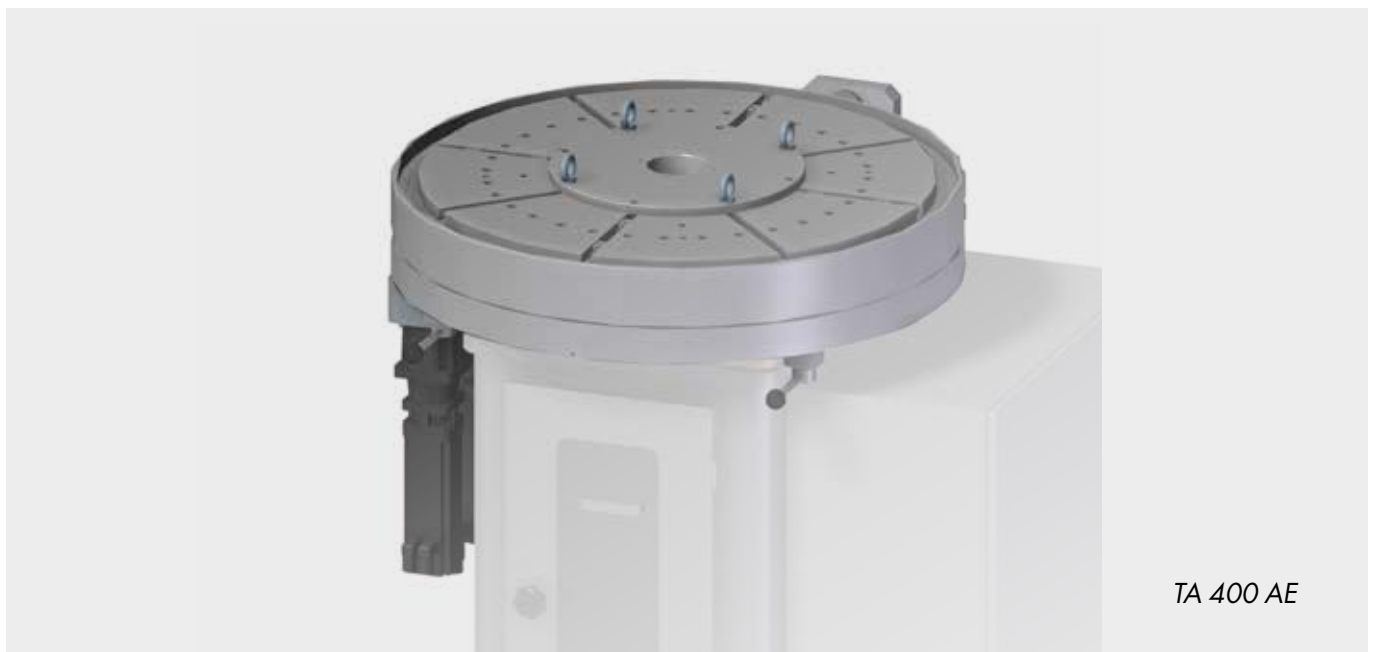

## Automatic Indexing Tables

In order to produce multi-groove profiles we recommend the use of automatic indexing tables. The standard equipment of the automatic indexing tables includes adaptor plates as stated for the manual indexing tables. Using the automatic indexing table will eliminate potential human errors.

The possible indexing facilities are: 2 - 360.

All movements of the table are controlled by the CNC of the machine. All electrical parts are mounted in the main electric cabinet. The zero point of the indexing table can be fixed in each position.



## Manual and automatic indexing tables for bores from 10 to 900 mm (depending on design) for use on FRÖMAG Keyseating and slotting machines

FRÖMAG Indexing tables are used for example, for the production of internal splines according to DIN or other standards, multiple keyways, helical gears, and other profiles or keyways apart from each other. Manual indexing tables are produced for bores up to 400 mm and can be equipped for direct or indirect division.

Automatic indexing tables are driven by servo motors. The computation (indexing) is effected electromechanically and controlled by the main machine CNC. The data is input at the touch screen of the control panel.

Automatic Indexing tables starting with the model TA400A and larger are equipped with two servo drives (Master and Slave). This mode of drive allows a backlash free revolution of the rotary table enabling the machining of internal helical splines.

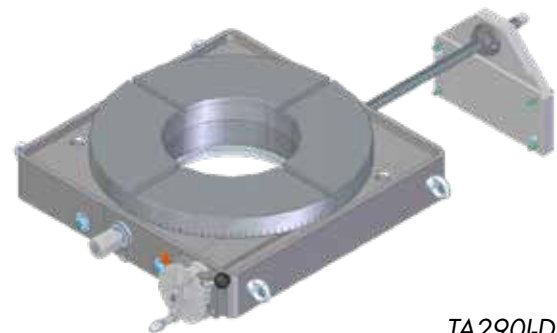

TA290I-D

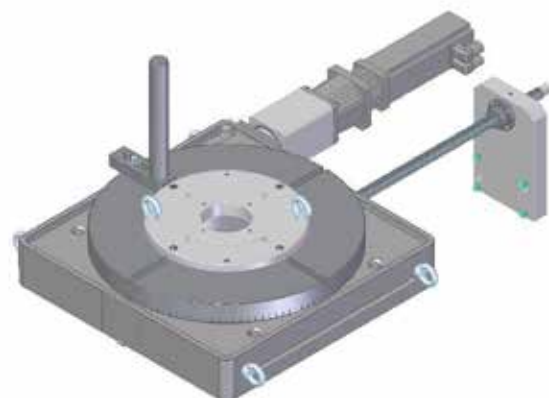

TA290A-1N

# Remote Service **SUPPORT**

---

Start increasing efficiency and saving costs:

### **Get your quote**

Simply send us the Serial number of your FRÖMAG machine. In return you get a detailed quote including a step by step explanation, showing the easy upgrade procedure.

### **Order your router**

Send us your order and don't miss the advantages of our Remote Service Support. Your router comes along with an instruction manual showing details on how to plug in.

### **Plug in and connect**

After unboxing, the remote router is plugged into the machine control cabinet. The router connects depending on ordered type via GSM or Ethernet. Any time you like to disconnect the machine simply unplug the router.



## Easy, Flexible, and Fast

The FRÖMAG Remote Support Router reduces costs and increases response time for the availability and maintenance of your FRÖMAG machines demonstrably.

After plugging in, the Remote Router connects the machine via Ethernet or GSM to the web. FRÖMAG service connects to the machine remotely for technical support, assistance or trouble shooting.

### **Safety first:**

Strong end to end encryption, two factor security authentication and standard measures to reduce risks of vulnerabilities are put in place. The machine can be disconnected or put offline as you require any time.

The key points at a glance:

- Easy plug-in installation to your machine
- Ethernet or GSM-connection available
- FRÖMAG connects to machine
- Online technical support and assistance
- Demonstrable reduction of downtimes
- Cost-effective avoiding travel time

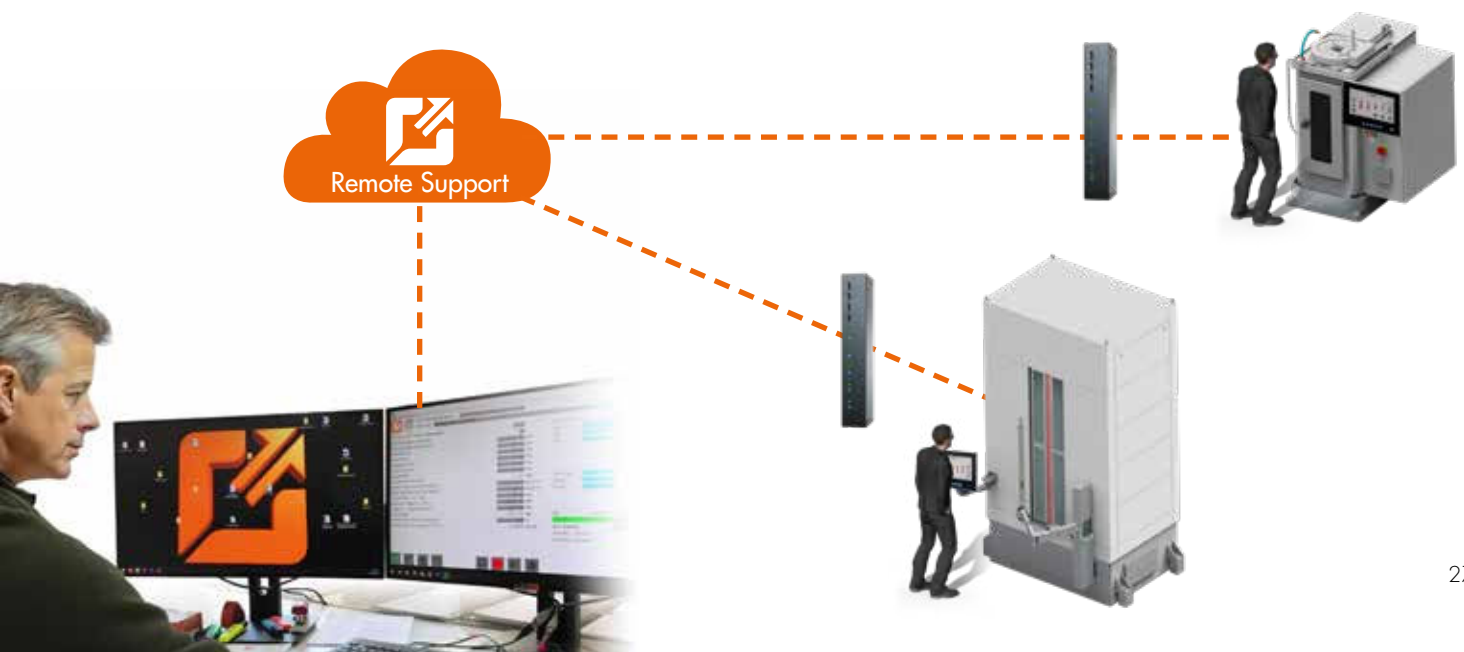



**Digitalization, new communication technologies and technical developments demand ongoing, continuing education in order to maintain our leadership position. FRÖMAG rises to this challenge every day.**

# INTERFACE

## RFID

Up to 15 operators can be managed.

The operators are divided into four groups. Each operator can be assigned up to 10 different access rights to the various parameters and functions of the control.

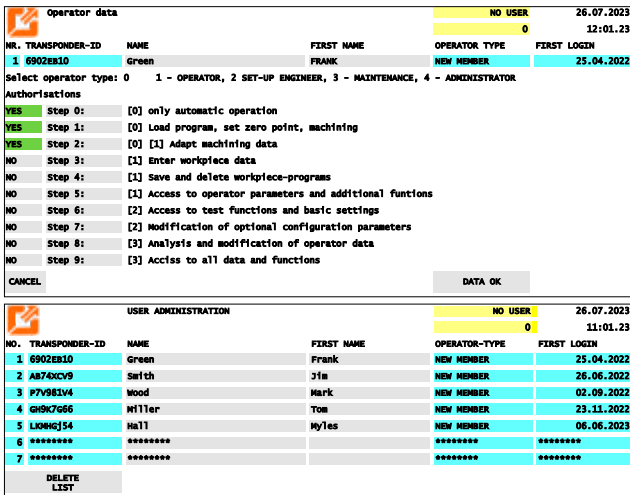

## Energy Monitoring

- Display of the current energy consumption
- Total consumption recording

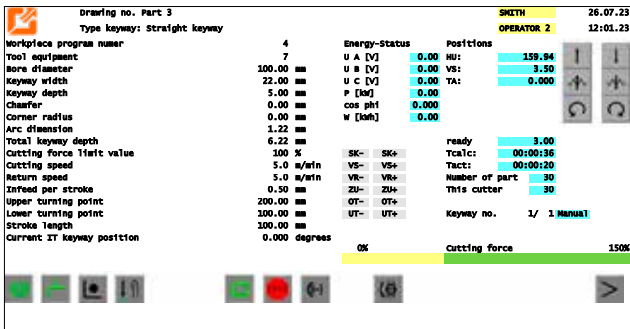

## OPC-UA

Following machine data are sent:

- Machine status
- Machining time
- Machining progress
- Active machining programme
- Operating hours
- Machine state error

Additional data / parameters on request

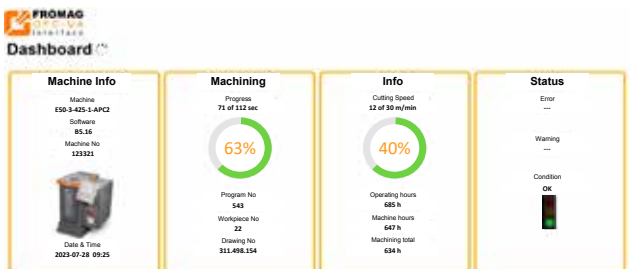

# RETROFIT

---



With a FRÖMAG retrofit, existing machines can be brought up to date. By furthering the use of mechanical components, machines can be given a second life. This program creates a money saving alternative to a new machine.

The essential points at a glance:

- Up to 30 % faster setup time
- Energy savings up to 10 %
- OEM FRÖMAG-Retrofit
- 1 year warranty
- FRÖMAG - OEM tooling and equipment
- Up to date safety conformity machine features
- Advanced features and touch screen display
- Intuitive operation with FRÖMAG user interface
- No programming required
- Optional remote maintenance feature
- Cost-effective alternative to a new machine

## Disassembly

The first step in the retrofit process is the disassembly of the machine. Wear parts, electrical components, and machine controls are dismantled and disposed of in a professional manner.

## Technical

After mechanical review, the machine will be equipped with the latest technical standards and safety measures. The scope of supply will include technical documentation.



*FRÖMAG  
CNC 70/600  
Manufacture date: 1989*

## Mechanics

After the initial disassembly, mechanical components are inspected for dimensional accuracy and wear. If necessary, these parts are then replaced.

## Result

The rigid FRÖMAG machine design, in conjunction with revised mechanical components and latest APC2 control is an excellent investment.



*Retrofit 2023  
with the latest  
APC2 Control*

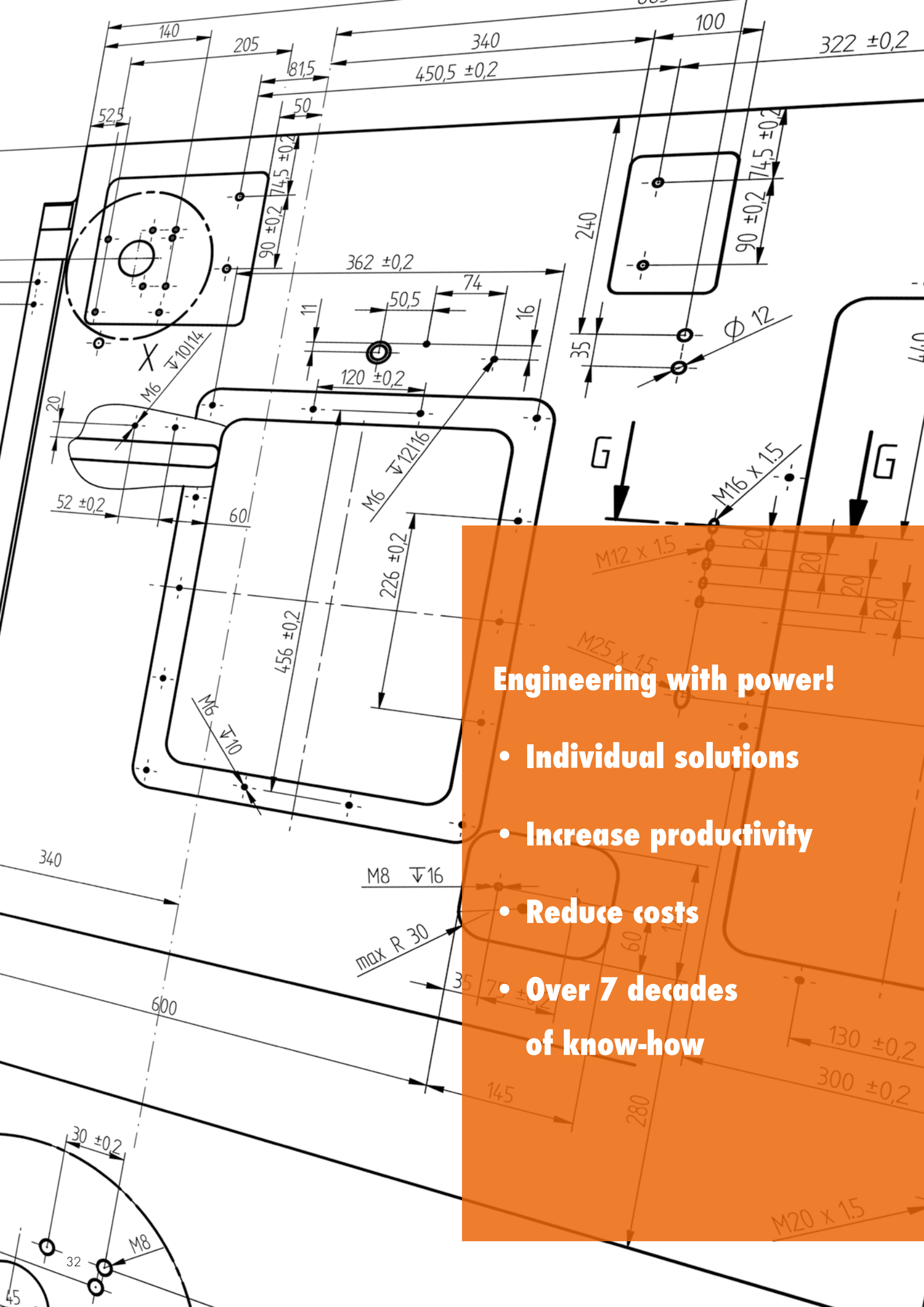

## Engineering with power!

- Individual solutions
- Increase productivity
- Reduce costs
- Over 7 decades of know-how



# Individual **SOLUTIONS**

---

In mechanical engineering, individual solutions are of great importance to increase productivity and reduce costs.

Through customised solutions, we can help your company meet your specific requirements and maximise your efficiency.

Our experts work closely with you to understand your requirements and develop innovative solutions. We analyse your production processes, identify bottlenecks and look for ways to increase productivity.

By using the latest technologies and advanced automation, we can develop customised solutions that are tailored to your specific needs. In doing so, we always make sure that the costs are kept in view in order to ensure an optimal cost-benefit ratio.

Our goal is to help you increase productivity while reducing costs. We firmly believe that there is a solution to every challenge and are ready to work with you to achieve exceptional results.

Do not hesitate to let us know your individual requirements. We look forward to assisting you with our customised solutions.



# The **CONTROL UNIT**

---



FRÖMAG machines feature a unique control concept which is continuously improved in cooperation with our customers and users.

The machine operator simply selects the work piece and tool-related data, which simplifies handling, considerably shortens the machine setup time and avoids errors.

- FRÖMAG machines are equipped with a touch screen for intuitive operation.
- More than ten languages are included in the default settings for operation.
- The control panel is integrated into a sturdy stainless steel housing. The housing is carried out in protection class IP69K.
- Storage spaces for 600 different work pieces are available to the user.
- Diagnosis functions provide information about the machine status in plain text.
- An effective and simple layout of the control cabinet is realised thanks to the decentralised I/O concept.



## **AUTOMATION**

FRÖMAG machines are designed for seamless integration into automated production processes.

Machine parameters are accessible via interfaces.

A large industrial machine shop with a yellow overhead crane and workers operating machinery. The crane is labeled 'COKIA 161'. The shop has high ceilings with large windows and various pieces of industrial equipment, including ladders and workbenches. Two workers in blue uniforms are visible, one on a ladder and another working on a machine. The floor is dark and there are several metal steps or platforms. In the foreground, there is a blue cart with tools and a wooden pallet with several metal parts.

**Keyway widths from  
1 - 300 mm and lengths  
up to 2500 mm and profiles  
up to 900 mm diameter.**

# Sub **CONTRACTING**

---

We manufacture for you · Competently, individually and reliably

For machining single keyways, multiple keyways, internal splines, tangential keyways, helical keyways, keyways in blind holes and other profiles different types of our newest electromechanical keyseating-and profiling machines are available.

Keyways and profiles from 1 up to 300 mm width with max. lengths up to 2500 mm and internal diameters between 10 and 1000 mm and a total weight up to 16t resp. 8m can be machined.

All machines are equipped with automatic indexing tables so that internal gears with any division can be machined, too.

## We are pleased to offer:

- Machining of single and multiple keyways in cylindrical bores
- Profiles: involute splines, radii, serrations, rectangulars, hexagons etc. oil and multiple grooves, tangential keyways, helical keyways
- Upcutting of keyways or profiles with guided or self-locating tools in blind holes with undercut

Our electromechanical driven machines are specially used for machining hardened materials, for example VA materials, Monell, Hastelloy, Inconel, etc.



**FRÖMAG provides extensive know-how and comprehensive experience to meet all of the requirements for machining your work piece.**

# The fitting **TOOLS**

---

With original tooling equipment and tools made by FRÖMAG you can count on perfectly matched products – everything from one supplier.

Our team of experts will support you in defining the process, tooling equipment and tools.

**Ordered today –  
delivered tomorrow**

Internal spline



Multiple keyways

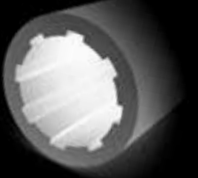

Conical keyways

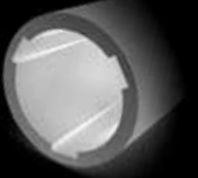

Tangential keyways

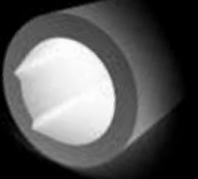

Internal splines in blind holes



Helical keyways

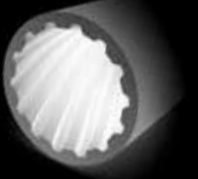

Keyways in blind holes

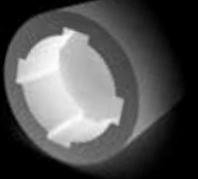

Lubrication keyways

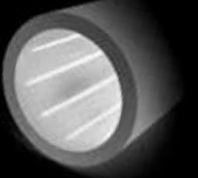





Maschinenfabrik  
**FRÖMAG**

Maschinenfabrik FRÖMAG GmbH & Co.KG  
Postfach 1261 · D-58718 Fröndenberg  
Am Klingelbach 2 · D-58730 Fröndenberg

Phone: +49 2373-756-0  
E-Mail: [info@froemag.com](mailto:info@froemag.com)  
[www.froemag.com](http://www.froemag.com)



Social:

-  [linkedin.com/company/froemag](https://www.linkedin.com/company/froemag)
-  [youtube.com/froemag](https://www.youtube.com/froemag)
-  [facebook.com/maschinenfabrik.froemag](https://www.facebook.com/maschinenfabrik.froemag)
-  [@froemag](https://twitter.com/froemag)
-  [@froemag](https://www.tiktok.com/@froemag)