



FOX SC500 FOX SC500 ATEX

AIR FILTRATION SYSTEMS
FOX SC 500
SPRAY CABIN



Air quality is one of the most important aspects in order to provide a healthy, clean and safe work environment. However the cleaning of oily parts with an air gun without protection releases a considerable amount of hazardous pollution. LNS' priority is to improve working conditions inside factories and workshops and in order to eliminate such pollution, LNS offers the FOX SC500 Spray Cabin, including a TÜV-certified ATEX version.



YOUR ONE-STOP-SHOP
FOR MACHINE-TOOL PERIPHERALS

FOX SC500

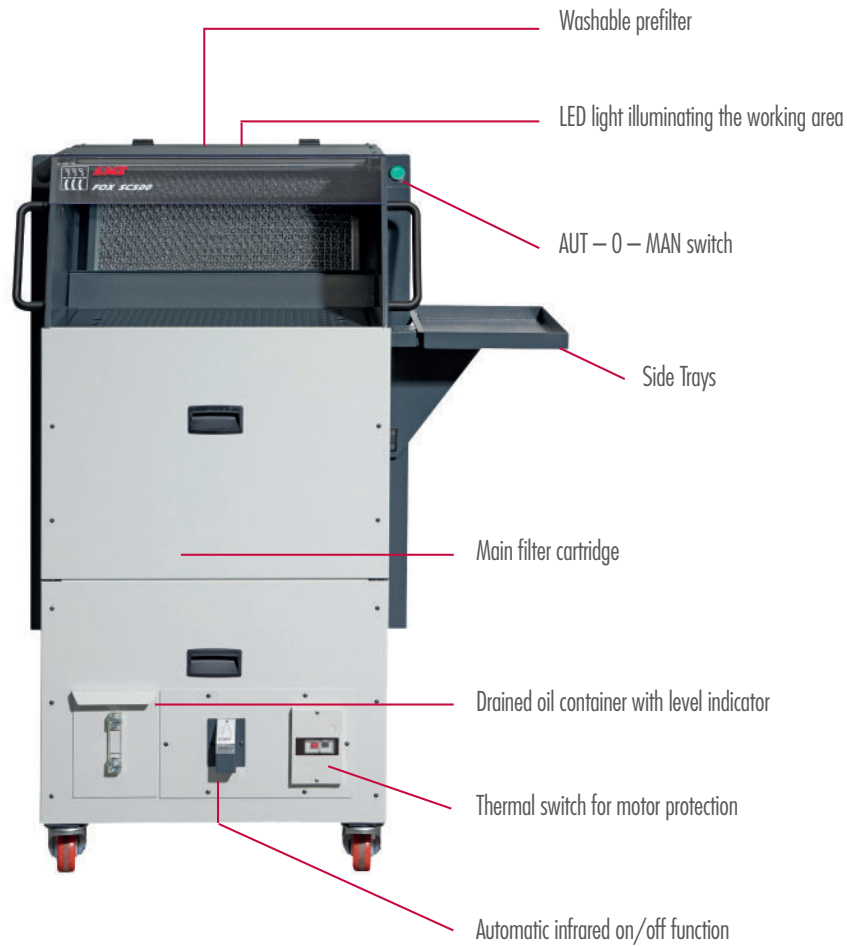

SPECIFICATIONS

- Mobile and compact
- Easy connection to standard wall plug
- High efficiency filtration > 99% (AFNOR 44060)
- Washable prefilter
- Low noise level
- Low electrical consumption

FOX SC 500		50 Hz	60 Hz
Motor	[kW]	0,37	0,4
RPM	[min-1]	2790	3350
Voltage / Phase / Frequency	[V/ph/Hz]	230/1/50	115/1/60
Nominal air flow	[m ³ /h] (cfm)	750	900 (530)
Sound level	[dB(A)]	67	69
Static pressure	[Pa]	610	890
Weight	(kg)	70	

- Information is subject to change without notice
- All units painted in RAL 7035/7016
- Standard electrical motor single phase [V/ph/Hz] 230/1/50 or optional three-phase motor [V/ph/Hz] 230/3/50 – 400/3/50

FOX SC500 ATEX



SPECIFICATIONS

- Mobile and compact
- High efficiency filtration > 99% (AFNOR 44060)
- Washable prefilter
- Low noise level

FOX SC 500 ATEX with TÜV certification for flammable solvents. For duties in an environment with potentially flammable solvents and degreasing agents, a special ATEX version is designed to handle the cleaning process without danger for the operator. While there are no electrical elements, all the functionalities offered to the user remain identical to the standard version.

FOX SC 500 ATEX		
Motor	[kW]	0.125 (air)
RPM	[min ⁻¹]	2500 (5 bar)
Voltage / Phase / Frequency	[V/ph/Hz]	-
Nominal air flow	[m ³ /h]	500
Sound level	[dB(A)]	72
Static pressure	[Pa]	490
Weight	(kg)	100

- Information is subject to change without notice
- All units painted in RAL 7035/7016

FLOOR PLAN (mm) FOX SC500

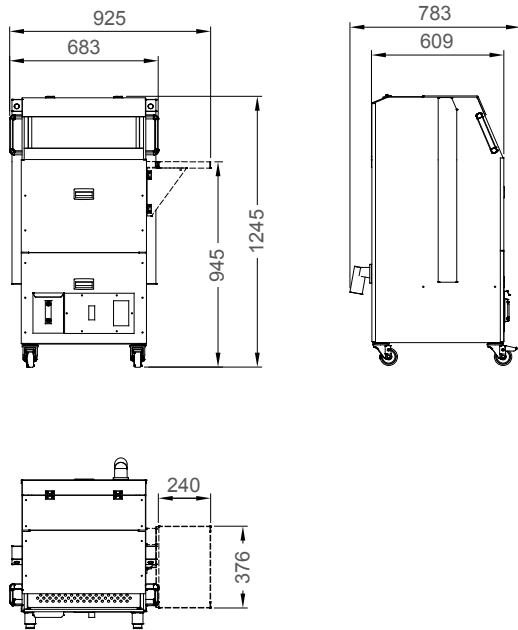

FLOOR PLAN (mm) FOX SC 500 ATEX

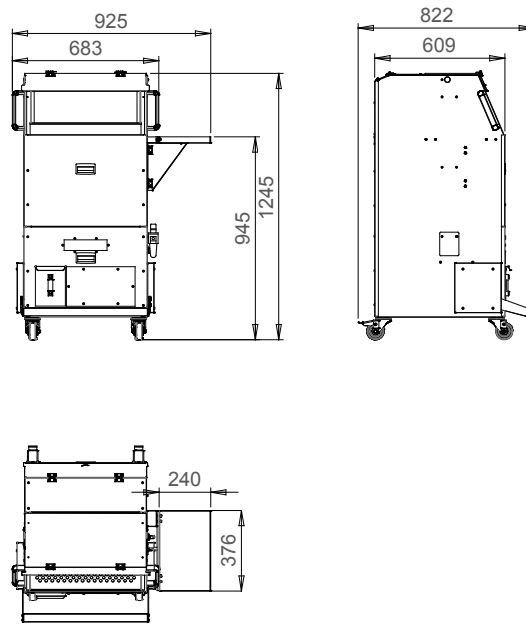

YOUR ONE-STOP-SHOP FOR MACHINE-TOOL PERIPHERALS

LNS provides a full range of bar feeders, chip conveyors, coolant management systems and air filtration systems which is second to none on the market. We are known in the industry for the solid expertise we have gained over several decades in an exceptionally wide range of applications, our excellent customer service and technical support. This support is ensured by highly qualified technicians who are available at key locations throughout Europe.



LNS SA
Route de Frinwillier
2534 Orvin
Switzerland

+41 32 358 02 00
LNS@LNS-europe.com
www.LNS-europe.com