



Logan FlexaDrive™ 800-1

Single Tower Pump Drive System For Engines up to 800 HP (600 kW)

Logan FlexaDrive™ Series Description:

Rated at 800 HP / 600 kW under continuous duty, the Logan FlexaDrive is a self-contained, single tower, multiple pump drive gearbox, which provides full engine power between your engine (power take-off) and transmission. Logan 800-1 FlexaDrive input and output housings mount to standard SAE No.1, No. 2 and No. 3 flywheel housings (SAE J617 and SAE J617 Flywheels) and to any specified drive shaft. FlexaDrives can be positioned up to 90° in either direction.

Tower Capacity: Various step-up gear ratios are available for the PTO Tower, with a maximum continuous duty rating of 350 HP / 260 kW. Standard pump drive tower ratios are 1:1 and 1:1.21. An integral Flexible coupling is required to dampen torsional vibration.

- Input and Output Housing SAE No. 1 – No. 3
- Tower Pump Pads SAE A – SAE D
- Continuously Duty Rated Through Drive
- Pump Drive Tower Capacity 350 HP / 260 kW
- Standard Pump Drive Tower Ratios are 1:1 and 1:1.21
- 2200 RPM Maximum
- Integrated Reservoir – Eliminates Need for Secondary Tank
- Positioned up to 90° in Either Direction

The Logan 800-1 Series is outfitted with (1) Tower, (2) PTO/PTI pads, accommodates up to 800 HP / 600kW input power, and can be positioned up to 90° in either direction.



Logan FlexaDrive™ 800-1



Maximum Torque Transfer Within Compact Axial Length

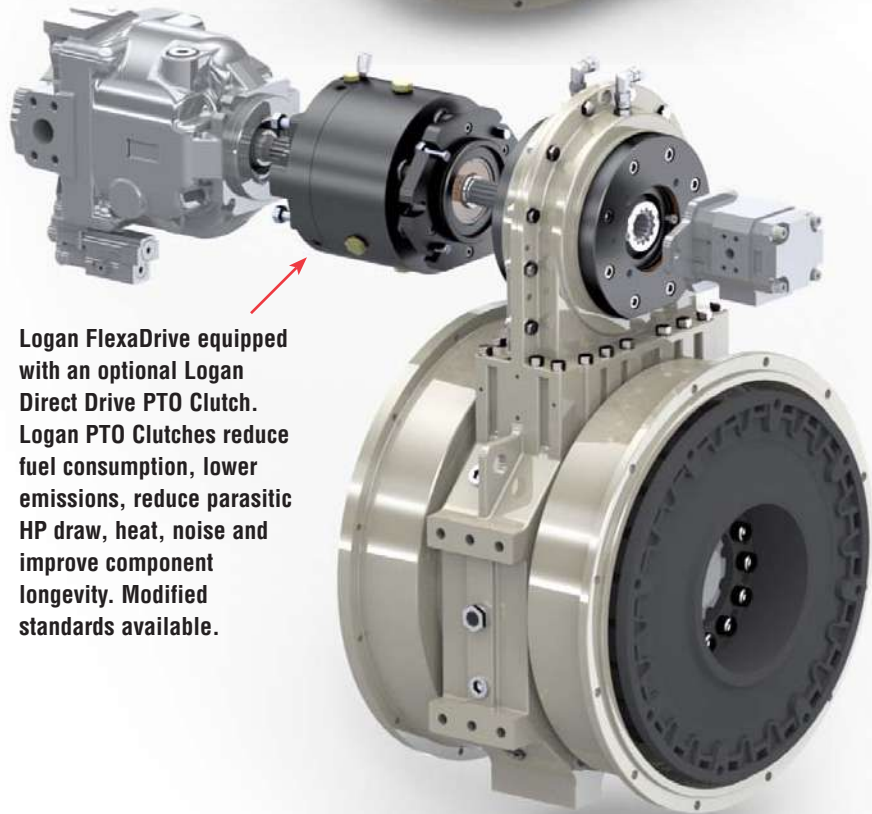

Logan FlexaDrive equipped with an optional Logan Direct Drive PTO Clutch. Logan PTO Clutches reduce fuel consumption, lower emissions, reduce parasitic HP draw, heat, noise and improve component longevity. Modified standards available.

Logan FlexaDrive™ 800-1

February 2022



Logan FlexaDrive™ 800-1

Single Tower Pump Drive System For Engines up to 800 HP (600 kW)

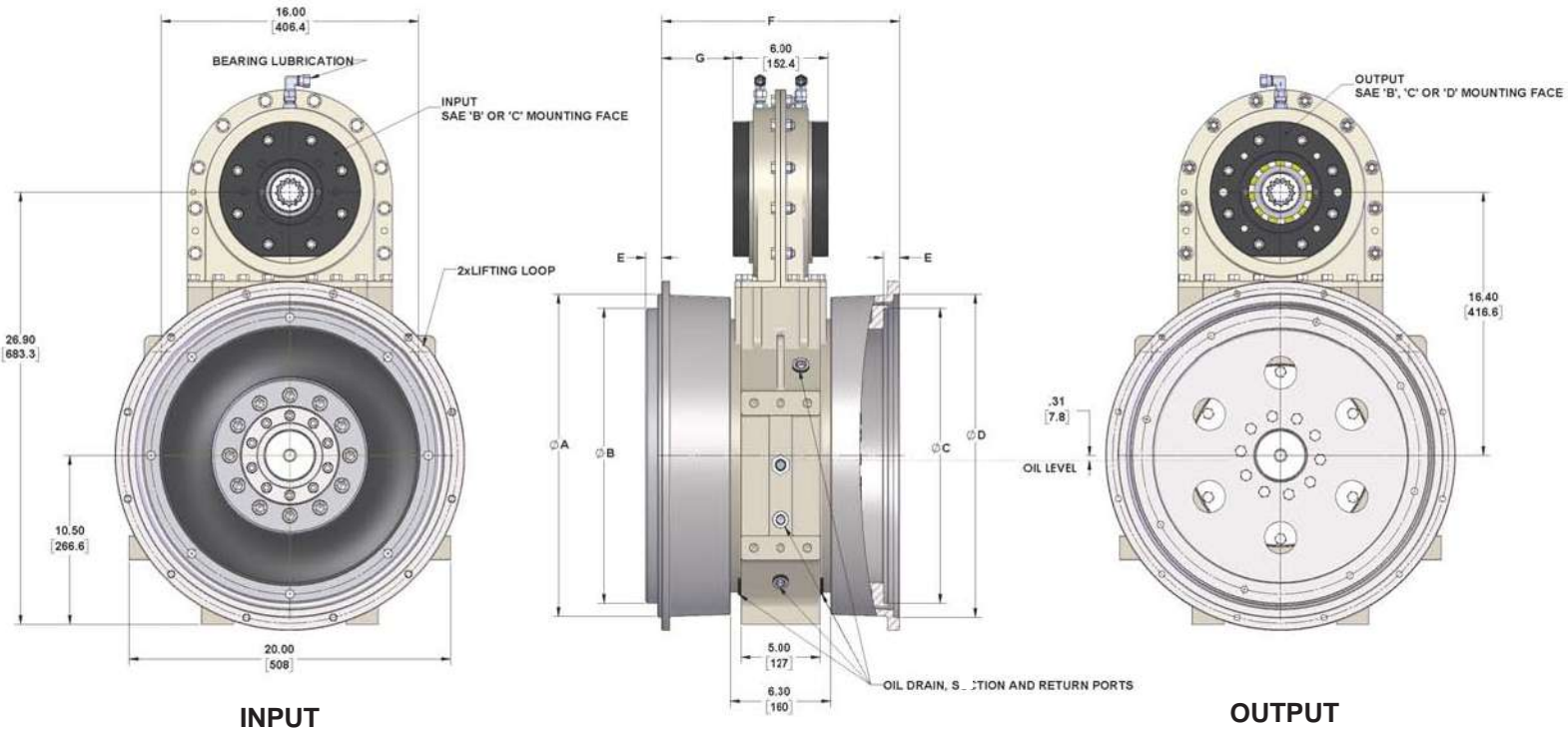

PUMP DRIVE INSTALLATION POSITIONS

Up to 90° in either direction

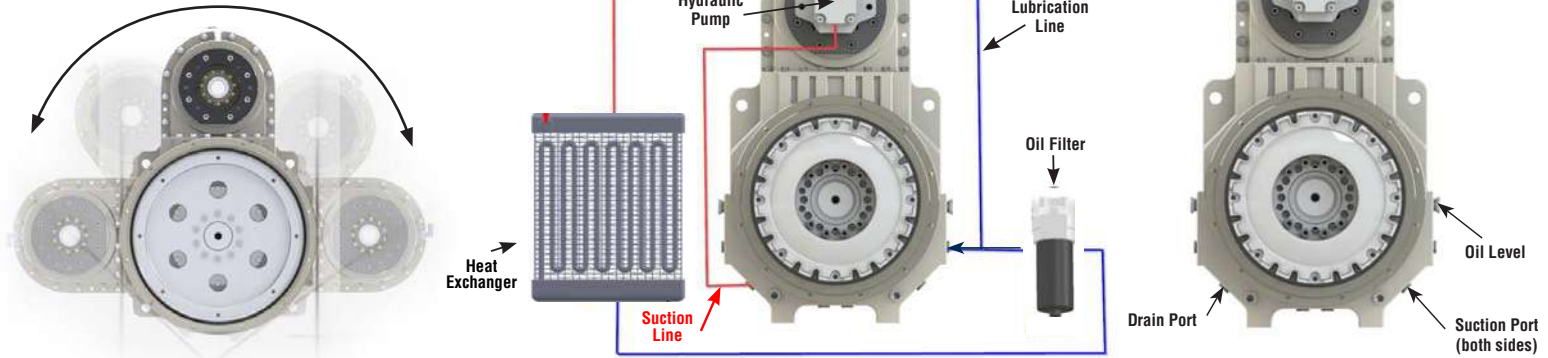

OPERATING PARAMETERS FlexaDrive™ 800-1

MAX. SHAFT SPEED 2200 RPM MAX.	MAX. INPUT POWER 800 HP / 600 kW	HEAD CAPACITY 350 HP / 260 kW	MAX. TOWER SHAFT SPEED @ 2200 RPM MAX.	GEAR RATIO 1:1; 1:1.21	OIL CAPACITY 3 Gal./11.4L
--	--	---	--	----------------------------------	-------------------------------------

INPUT / OUTPUT				A/D [in/mm]	B/C [in/mm]	E [in/mm]	F [in/mm]	G [in/mm]	WEIGHT** [Lbs./kg]	
FlexaDrive™ 800-1	J617	SAE 1	J620	SAE 14"	20.125/539.75	18.375/466.73	1.00/25.4	14.84/377.1	4.42/112.3	705/320
		SAE 2		SAE 11.5"	17.625/447.67	13.875/352.43	1.563/39.69	13.13/333.5	3.15/80	635/288
		SAE 3		SAE 11.5"	16.125/409.57	13.875/352.43	1.563/39.69	13.13/333.5	3.15/80	620/282

OUTPUT: MOUNTING AVAILABLE FOR COMBINATIONS OF SAE J617 HOUSINGS AND SAE J620 FLYWHEELS AND FOR ANY CUSTOMER SPECIFIED DRIVE SHAFT.

* Continuous duty. Modified standards available to meet specific OEM requirements.

** Weight without oil. Weight of oil approx. 25 Lbs./11.4 kg.

February 2022