

RAAL[®]
complete *cooling* solutions



Cooling solutions for
CONSTRUCTION & MINING EQUIPMENT



Starting from a simple cooler to a complete cooling system, **RAAL** always offers the best solution in terms of performance, profitability and compliance with environmental standards and it adds value to the products of its partners.

A permanent challenge for **RAAL** is to provide the OEM dealing with construction and mining equipment dedicated cooling solutions that are ready to face the extreme conditions.

More than half of the **RAAL** production is designed for the off-road equipment and machinery.

Flexibility, experience and innovation, as reflected in the **RAAL** products, satisfy the highest demands.



AIR COOLED COOLING SYSTEM FOR OFF-ROAD EQUIPMENT

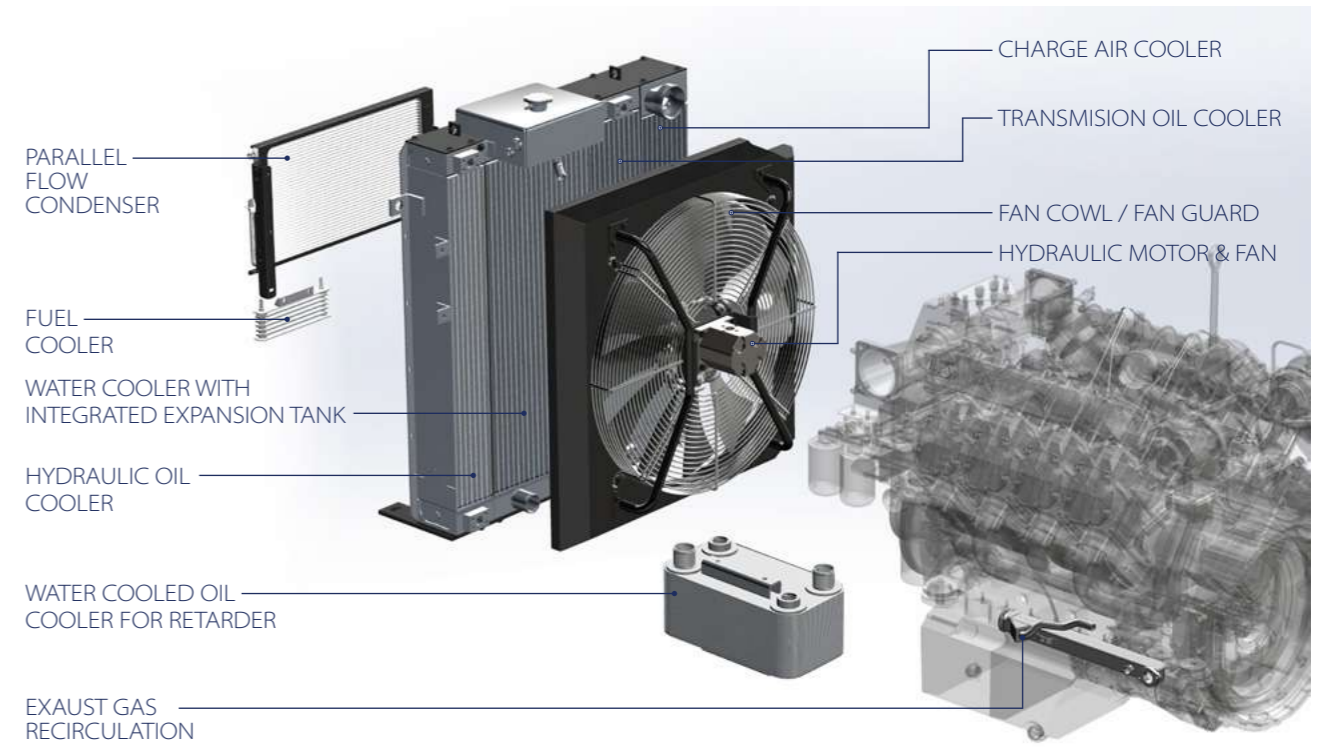

COOLING SYSTEM WITH WATER COOLED AUXILIARY CIRCUIT FOR OFF-ROAD EQUIPMENT

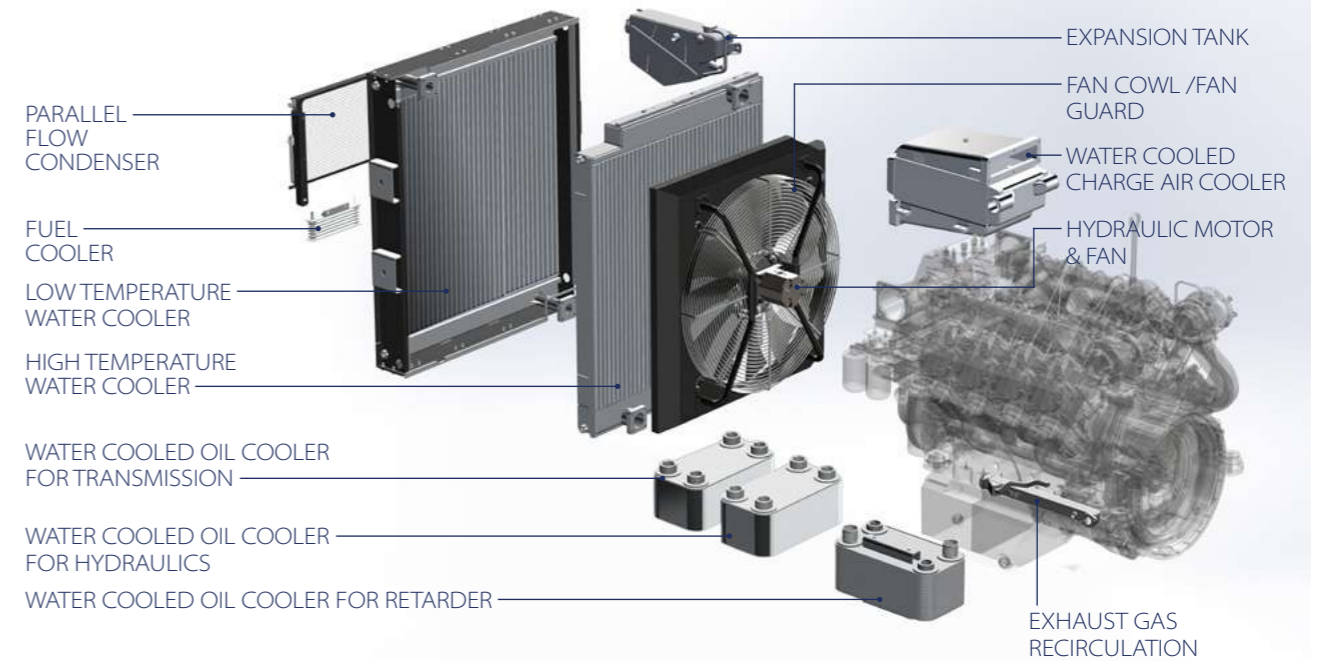

EQUIPMENT AND APPLICATIONS IN CONSTRUCTION AND MINING INDUSTRIES



- Loaders
- Excavators
- Bulldozers
- Drilling Equipment
- Forklifts
- Cranes
- Telehandlers
- Articulated Dump Trucks
- Rigid Dump Trucks
- Compactors
- Crushers
- Asphalt & Concrete Pavers
- Motor Graders
- Mining Equipment
- Special Equipment





ADVANTAGES AND BENEFITS OF RAAL'S CUSTOMERS

Flexibility and customized solutions

The modular heat exchangers and cooling systems are adapted to the customers' needs and are developed together with them.

- tens of thousands of different products
- 300 products of different size and type in production, monthly
- hundreds of applications
- lots from one to tens of thousands of units

Experience and expertise

Each customer and each application is important for **RAAL** and, in this regard, it has trained and specialized its teams in different fields and applications (R&D, tool and die design, manufacturing, sales, logistics, marketing) that reached 30 years of experience.

Short terms, competitive prices

RAAL is an integrated company that offers short-term product development / delivery at competitive prices.

Innovation, technology and performance

RAAL has a strong and creative research and development department that has been prepared to deliver performance.

- 150 engineers
- a well-equipped test center
- patents for fins&fin forming machines and new design /technology solutions
- investment in the latest equipment and technologies
- 50 prototypes per month
- 30-50 days for the development of a new product

Environment protection

RAAL offers compact and lightweight products with minimal impact on the environment due to reduced consumption of materials and fuel.

- advanced cooling solutions that comply with the new environmental regulations on polluting emissions (Tier 4F, etc.)
- 100% recyclable products
- Environmental Management System according to EN ISO 14001:2004.

Quality and reliability

RAAL meets the highest quality standards (ISO9001, ISO/TS16949, etc.)

Years of uninterrupted operation of its products, which have shown no operation failures, have proven that **RAAL** can provide heat exchangers that are able to withstand the harshest operating conditions.

- extended warranty terms (24 or 36 months)
- post-sale services.

Long-term partnership

The mutual trust, openness towards the latest technical solutions and customer approach are the core values of **RAAL**, that guarantee a long-term business relationship.

The **RAAL** cooling systems equip the top range equipment of major OEM customers

- over 50 customers within this field

Features of the RAAL aluminum cooling systems for construction and mining equipment

- solid design for extreme operating conditions
- compact structure
- modular solution using design types and various configurations
- "drop-in-place" concept for integration in equipment
- special-design fins for soiling prevention



PRODUCT RANGE



COMPLETE COOLING SYSTEMS, comprising brazed aluminum heat exchangers manufactured in the following different designs and other components:

- Radiators, Oil coolers, Charge air coolers, Fuel Coolers, Condensers
- Metallic structures, including fan cowls and protection grids
- Fans, motors



Brazed aluminum **OIL COOLERS** manufactured according to the following design solutions:

- Plate&Bar
- Shell
- Brazed plates
- In-tank plate type
- Tube&Fin



Brazed aluminum **RADIATORS** manufactured according to the following design solutions:

- Plate&Bar
- Tube&Fin
- Shell
- Manifolds



Brazed aluminum **CHARGE AIR COOLERS** manufactured according to the following design solutions:

- Plate&Bar
- Tube&Fin
- Shell



Brazed aluminum parallel flow **CONDENSERS** with micro-channels and tubular collectors.

BRAZED STAINLESS STEEL HEAT EXCHANGERS manufactured according to the following design solutions:

- Brazed plates
- Plate&Bar
- Tube&Fin
- Shell



ENGINEERING

RAAL is an integrated company, all activities (manufacturing, design, testing, etc.) being carried out "in house". This competitive advantage provides both a very short development and assimilation cycle in production of new products as well as short term manufacturing and supply of series production.

• Design, calculation and simulation

RAAL uses its own dimensioning software for heat exchangers, software developed in-house based on theoretical studies and thousands of tests performed.

RAAL uses FEA (Finite Element Analysis) to simulate the structural, flow and vibration stress conditions.

• Product design

RAAL has vast experience in designing heat exchangers and cooling systems. Starting from the specifications, dimensions or CAD data of the application, RAAL designers are able to find the best solutions for the most efficient use of the available space.

RAAL designers have the ability to continuously optimize the products, so as to fully meet the requirements of the application.

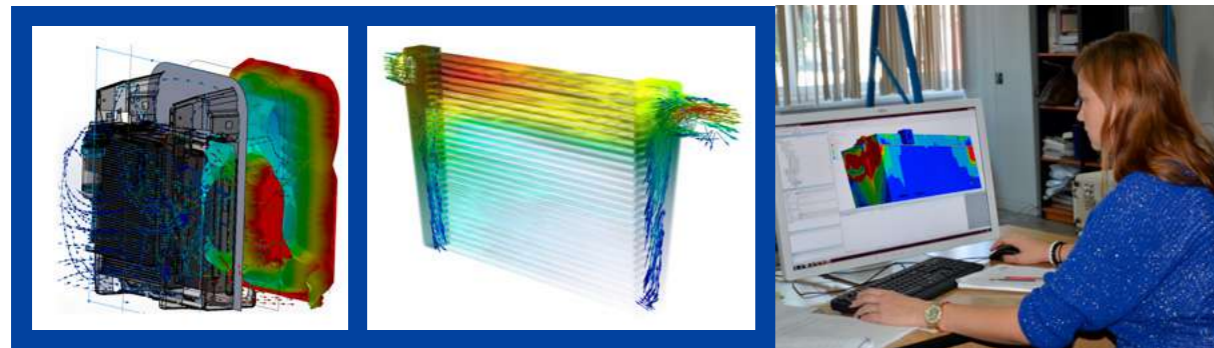

• Testing and validation

RAAL Testing Center is the facility where the validation of new products is performed. Based on technical specifications or on the parameters obtained by means of DAQ performed on customer equipment, the heat exchangers are tested for performance and strength.

RAAL Testing Center capabilities:

- thermal and fluid-dynamic performance tests on the wind tunnel
- burst pressure, performed at ambient or at high temperatures in the climate chamber
- durability tests: shock and vibration
- internal cleanliness tests
- durability tests: thermal cycle, pressure cycle,
- chemical and accelerated corrosion tests
- metallographic studies



• Tools and equipment

RAAL engineers have a vast experience in tool and die design, and in designing the specific equipment necessary for the manufacturing process.

RAAL places special importance on the design, manufacturing and optimization of the new generation of fin forming machines, which provide a wide range of fins and turbulators.

QUALITY

All RAAL products are manufactured in compliance with the following standards:

- ISO 9001:2008 and ISO/TS 16949:2009 - Quality Management System.
- EN ISO 14001:2004 - Environmental Management System
- OHSAS 18001:2007 - Occupational Health and Safety Management System

Main Factories



Headquarters and manufacturing facilities: RAAL SA, ROMANIA
Str. Industriei, nr.7, 420063, **Bistrița**
Phone: +40 263 234379,
Fax: +40 263 234507,
E-mail: raal@raal.ro



**Cooling Systems Factory
Prundu Birgaului, ROMANIA**
nr. 25, 427230, **Prundu Birgaului**
jud. Bistrița-Năsăud,
Phone: +40 263 203315, Fax: +40 263 203317,
E-mail: productie@raal.ro

Subsidiaries



RAAL ITALIA, ITALY
Via G. Finati 53, 44100 **Ferrara**
Phone: +39 0532773637, Fax: +39 0532776476,
Mobile: +39 3487900168, E-mail: info@raal.it



RAAL-Deutschland GmbH, GERMANY
Bauhofstraße 4 D-90571 **Schwaig**,
Phone: +49 (0)911 650 90 66-5, Fax: +49 (0)911 650 90 66-10
Mobile: +49 (0)162 294 27 19, E-mail: oana.eccedi@raal-gmbh.de



Atlas Engineering LLC, USA
30440 Industrial Rd, **Livonia, Michigan** 48150,
Phone / Fax: +1.734.427-2926, Mobile: +1.734.657.8262
E-mail: septimiu.n.puscas@atlasengllc.com



RAAL Holland B.V., HOLLAND
Dirk Dronkersweg 4462, **Goes**
Phone: +31 113348933, Fax: +31 113348937
Mobile: +31 613308061, E-mail: ja@raal.nl



www.raal.ro

