

# IKA®

## Master Plant MP



Designed  
to work perfectly

# Master Plant MP

2 Innovative solutions thought-out in detail

## Applications

### Food:

- Sauces
- Dressings
- Mayonnaise
- Liquid spices
- Cheese spread
- Ready-to-serve-meals
- Baby food
- Jams
- Pet food

- Starch solutions
- Alginate

### Beverage:

- Fruit juices
- Vegetable juices
- Milkshakes
- Protein drinks
- Liqueurs
- Sugar solutions
- Flavours

### Cosmetics:

- Creams
- Sun protection products
- Perfumes
- Shaving cream
- Decorative cosmetics
- Shampoo
- Body-care products
- Conditioners
- Hand washing paste
- Liquid soap
- Tooth paste
- Collagen suspensions
- Carbopol emulsions



IKA® homogenizing and emulsifying system Master Plant allows for efficient mixing, dispersing, heating/cooling, and optimum feeding of additives. The innovative GMP-conform mixing plant enables the processing of high viscous products, also under pressure and vacuum.



MP 10



MP 25



MP 50



MP 100



MP 200

**Connections**  
for vacuum, compressed  
air or funnels for additives

**Control monitor**  
with touch  
screen

**Load ceels**

**Integrated  
control  
cabinet**

**Counter-rotating  
agitator  
with scraper**

**Feeding funnels** for  
powders and liquids

**Circulation loop**

**Dispersing machine  
DBI 2000** removable to  
the side

## Applications

### Pharmaceutical industry:

- Ointments
- Gels
- Eye drops
- Eye ointment
- Cough mixtures and similar
- Infusion solutions
- Sugar-/salt solutions
- Suppository masses
- Coatings
- Lotions (W/O resp. O/W)
- Paraffin emulsions
- Lipid emulsions
- Disintegration of vegetable substances
- Antiseptics
- Serum
- Vaccines

### Chemical industry:

- Cleaning agents
- Polishing agents
- Sliding agents
- Lubricant
- Hotmelt adhesive
- Corrosion protection agents
- Wax emulsions
- Ceramic suspensions
- Polymer emulsions
- Silicone emulsions
- TiO<sub>2</sub>-suspensions
- Colloidal solutions
- Catalyst suspensions
- Impregnating agents
- Pesticides, Fungicides

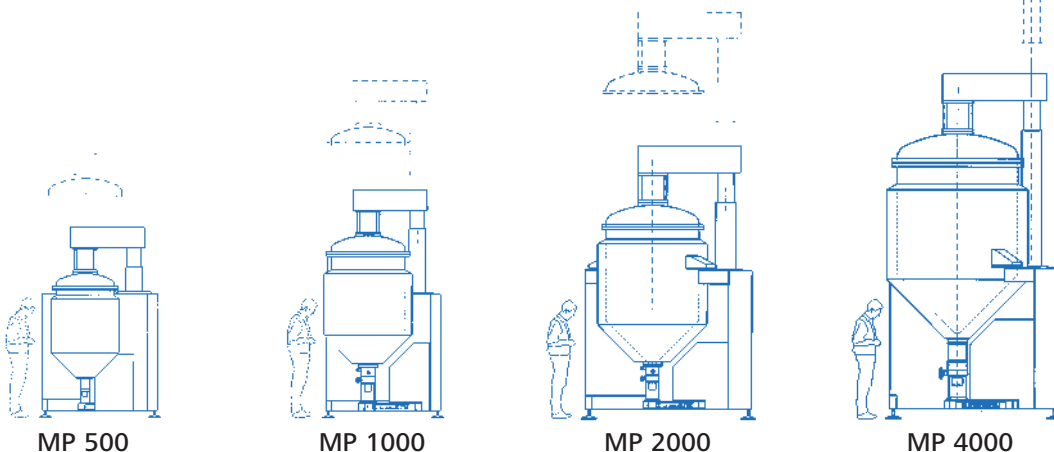

MP 500

MP 1000

MP 2000

MP 4000

# DBI 2000

4 Pumping, suction, mixing, dispersing

## DBI 2000 Function principle:

**The pumping rotator** creates suction within the system for circulation and for mixing at low shear stresses. At high speed it builds pressure up to 4 bar and creates a significant flow capacity which is very beneficial for CIP-cleaning.

**Diaphragm valve** between inlet and dispersing chamber. This creates the necessary negative pressure for aspiration of additives without applying vacuum in the mixing vessel.

**Outlet** into circulation loop with short or long circuit depending on batch size

**Discharge**

**Agitator blades** for processing small batches are located in the base of the conical section of the vessel. These also support the pumping highly viscous products.

**Piston valve** in an execution free of dead zones guarantees for avoiding of remaining quantities. Best cleaning possible.

**Feeding** of solid or liquid additives directly into the dispersing chamber results in fast and complete wetting that avoids the formation of lumps.

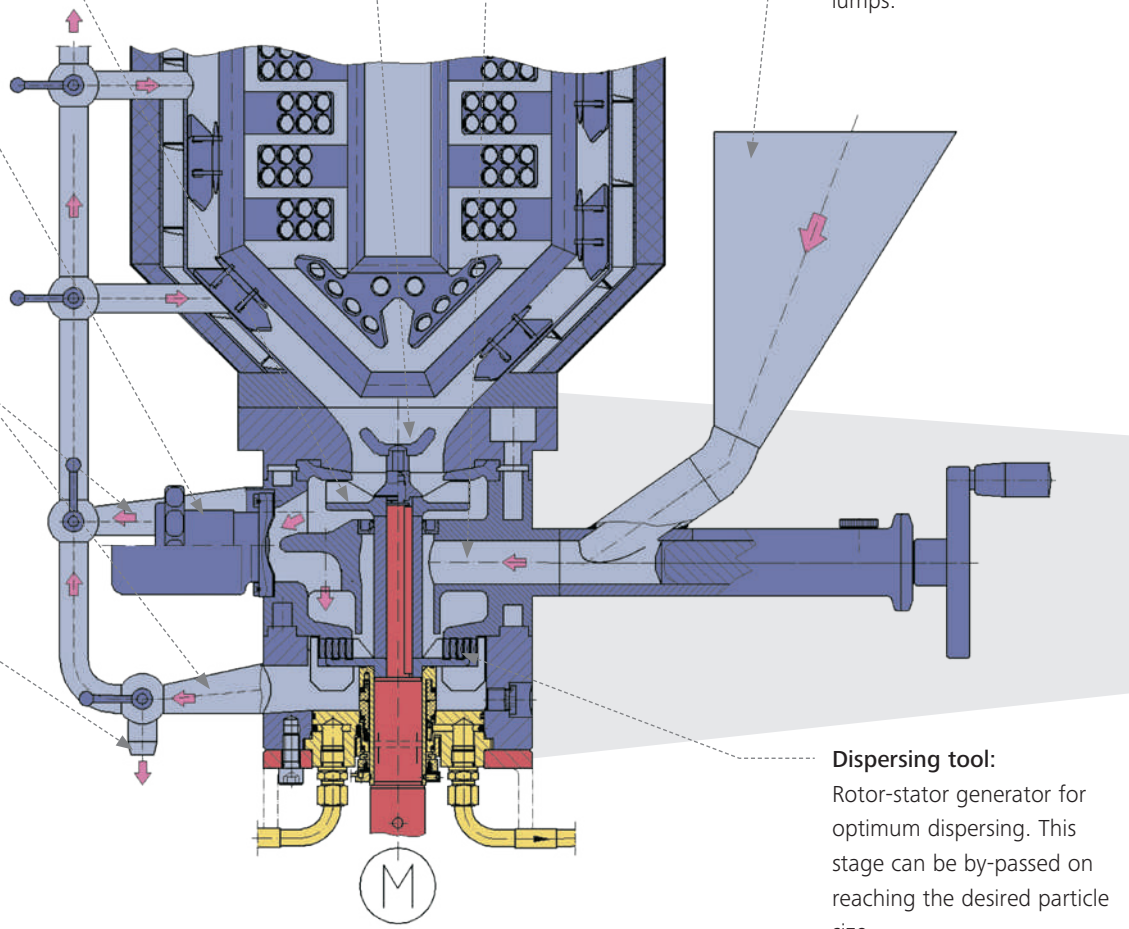

**Dispersing tool:** Rotor-stator generator for optimum dispersing. This stage can be by-passed on reaching the desired particle size.

To evolve, companies must grow. Growth requires additional production facilities. To be competitive the processes must be efficient.

**IKA® is aware of these issues and have the right solutions.**

We left traditions behind us and developed a new and compact machine. The mixing/dispersing machine model **DBI 2000**, for which patents are applied, combines the following functions in one unit:

**Pumping, Suction, Mixing, Dispersing, Cleaning**

## Direct Batch Inline

The DBI 2000 is the heart of the universal, practice oriented mixing plant MP. Innovative technical details enable better process data and reduced processing times at optimum dispersing quality and extremely wide viscosity range.



Dispersing machine DBI 2000/04

- Separate feeding of solid and liquid additives directly into the dispersing chamber
- No necessity for vacuum in the vessel
- No floating of powders or difficulties in wetting



## You already have a plant or you build plants?

This innovative machine also allows you to improve existing plants and to update them to the state-of-the-art, but you may also incorporate it into new plant conceptions. Our engineers will be pleased to give you advise.

# Master Plant

6 An innovative range delivering quality, price and performance

The **cover lock** is available in two versions, depending on the process pressure: As a clamping ring (quick locking) or as conventional bolting version.

The cover is lifted and lowered by means of a spindle drive in the **lifting column**. Operational safety is guaranteed by electrical and mechanical interlocks. Additionally the cover can be swung through 135 degrees for better maintenance and visual inspection.

## Scale-up from laboratory to the large-scale production

Develop new products and optimize your processes with the IKA® systems Master Plant in the laboratory and pilot plant sizes MP 10, MP 25 or MP 50!

The same design, comparable geometries of working tools as well as identical operation possibilities provide an easy scale-up of the developed processes to plants with higher batch volumes.



Master Plant MP 1000 with partially lifted counter-rotating agitator



Pilot system Master Plant MP 50 with two funnels for separate feeding of liquid and solid additives

## Two alternative agitator geometries

The Master Plant is available with two different agitators: The counter-rotating agitator for excellent and even mixing of the vessel content. Optimum vertical and horizontal mixing. The inner agitator can be heated/cooled, thus shortening the time necessary for heating or cooling. Suitable for viscosities up to approx. 100.000 mPa.s.

The spiral agitator can be completely heated or cooled. This shortens the time necessary for heating or cooling by up to 40%, thus offering significant advantages especially for cooling and stabilization of emulsions. Suitable for viscosities up to approx. 30.000 mPa.s.

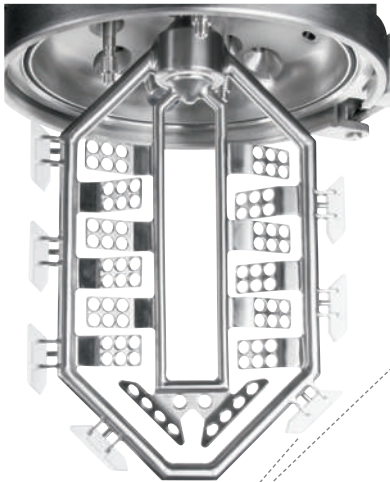

Movable scraper

## Electronic control with large touch screen:

- All essential process data are indicated
- Graphical operator surface
- Optional:
  - Formulation entry
  - Automatic operation
  - Network connection

## CIP-cleaning:

A minimum of three spray nozzles ensures thorough cleaning without dead spots or shadow areas. Sufficient pressure and throughput to feed the spray nozzles is created by the dispersing machine DBI. There is no need for additional CIP-pump.

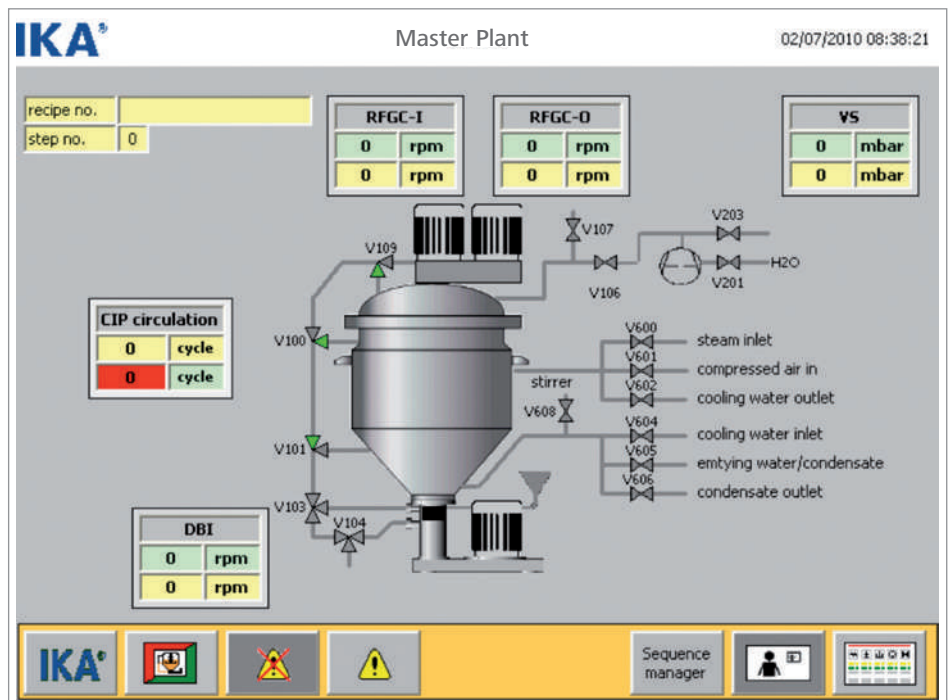





**IKA® QUALITY**

### **Essential advantages of the Master Plant**

- Viscosity range from liquid to paste (approx. 100 Pa·s)
- Feeding of solid or liquid additives without vacuum in the mixing vessel
- Formation of lumps is avoided by direct feeding of the additives into the dispersing chamber
- Treatment of smallest quantities down to approx. 15% of the nominal volume
- Separated circulation loop (short/long) for minimizing of dead spots and loss of material
- Important reduction of heating or cooling times, due to the heating/cooling of the spiral agitator
- Counter-rotating agitator on choice for highest viscosities, the inner agitator can be heated/cooled
- Multifunctional pumping- and dispersing machine DBI 2000/..
- CIP-cleaning, for which the DBI 2000/.. serves as pump and feeds the rotating spray nozzles
- Exchangeable dispersing tools
- Mixing and dispersing quality adjustable
- Low maintenance required
- The geometry of vessel and mixing units enables excellent scale-up possibilities
- The complete plant can also be supplied in Ex-protected execution acc. to the 94/9 EG (ATEX 95) guidelines
- The complete plant can be sterilized with steam (SIP)
- Direct steam injection is optionally available
- Customer specific execution on request



Master Plant	MP 10	MP 25	MP 50	MP 100	MP 200	MP 500	MP 1000	MP 2000	MP 4000
<b>Mixing vessel (l)</b>	13	32	65	130	260	650	1.350	2.600	5.200
Useful volume (l)	10	25	50	100	200	500	1.000	2.000	4.000
Working pressure in the vessel (bar)	-1 to 2,5	-1 to 2,5	-1 to 2,5	-1 to 2,5	-1 to 2,5	-1 to 2,5	-1 to 2,5	-1 to 2,5	-1 to 2,5
Max. temperature in the vessel (°C)	150	150	150	150	150	150	150	150	150
<b>Counter-rotating agitator</b>									
<b>Inner agitator</b>									
Motor power, kW	0,37*	1,1	1,5	2,2	3	5,5	7,5	15	22
Output speed at 20-60 Hz, min <sup>-1</sup>	120-360	90-270	66-198	54-162	43,2-129,6	32,4-97,2	24,8-74,4	20,4-61,2	16,8-50,4
<b>Outer agitator</b>									
Motor power, kW	0,37*	0,55	0,75	1,1	1,5	2,2	4	7,5	11
Output speed at 20-60 Hz, min <sup>-1</sup>	40-120	30-90	22-66	18-54	14,4-43,2	10,8-32,4	8,4-25,2	6,8-20,4	5,6-16,8
<b>Dispersing machine</b>									
Type	DBI 2000/04		DBI 2000/05		DBI 2000/10		DBI 2000/20		
Max. capacity (H <sub>2</sub> O) when dispersing (l/h)	2.000	2.000	2.000	5.000	5.000	15.000	15.000	20.000	20.000
<b>Electric control</b>	Cover and agitator via switch, DBI via Process-Pilot-Controller	Operation of the plant via an HMI (Human Machine Interface) in the control cabinet Operation unit: Colour-TFT-display 10,4" with touch screen							
<b>Dimensions (counter-rotating agitator)</b>									
Height (closed cover), mm	1.065	1.637	1.817	2.305	2.421	3.315	3.749	4.951	5.100
Height (open cover), mm	1.515	2.086	2.417	2.950	3.376	4.615	5.499	7.051	7.300
Width, mm	635	850	850	1.215	1.215	1.650	1.650	2.210	2.210
Depth, mm	661	1.010	1.010	1.407	1.407	1.900	1.900	2.710	2.710

\* One shared drive for both agitators



**IKA®-Werke GmbH & Co. KG**

Janke & Kunkel Str. 10  
D- 79219 Staufen

Tel. +49 7633 831-0  
Fax +49 7633 7087  
E-mail: process@ika.de

www.ikaprocess.com  
www.processworld-online.com



DIN EN ISO 9001  
Reg. Nr. 004343QM